

Heat pump

Gas HP 35 A (LT/HT)



After Sales Service guide

CONTENTS

1 INTRODUCTION	4
1.1 Symbols	4
1.2 Terms and abbreviations	4
1.3 Liability	4
1.3.1 Manufacturer's liability	4
1.3.2 Installer's responsibility	5
1.3.3 User's responsibility	5
1.4 Supplementary guidelines	5
2 SAFETY INSTRUCTIONS AND RECOMMENDATIONS	6
2.1 Safety instructions	6
2.2 Recommendations	6
3 TECHNICAL DESCRIPTION	7
4 THERMAL DESIGN	8
4.1 Control design	8
4.2 Hydraulic design	8
4.2.1 Buffer vessel	9
4.3 Hydraulic diagrams	9
5 GENERAL INSTALLATION	11
5.1 Installation instructions	11
5.2 Important points to consider	11
5.3 Noise and vibrations	11
5.3.1 Noise	11
5.3.2 Vibrations	12
5.4 Frost protection	12
5.4.1 Defrosting cycle	12
5.5 Water treatment	13
6 INSTALLING A SINGLE HEAT PUMP	14
6.1 Scope of delivery	14
6.2 Hydraulic installation	14
6.2.1 Hydraulic connections	14
6.2.2 Gas connections	14
6.2.3 Connecting the condensate drain pipe	14
6.3 Electrical connections and control - general	14
6.3.1 Connecting to the main power supply	14
6.3.2 Controlling the heat pumps via a 0-10 V signal	14
6.3.3 Controlling the heat pumps via an On/Off signal	14
6.3.4 Connecting a water circulation pump	14
6.4 Electrical connections and control - OpenTherm	14
6.4.1 Introduction to the CAN-bus	15
6.4.2 Connecting the CAN-bus to the Gas HP heat pump	16
6.4.3 Connecting the CAN-bus to the CAN-OT interface - two nodes	17
6.4.4 Connecting the CAN-bus to the CAN-OT interface - several nodes	18
6.4.5 LED signals for CAN-OT interface	19
6.4.6 Setting CAN-bus address on the Gas HP heat pump	19
6.4.7 Connecting the Remeha OpenTherm controller	20
7 INSTALLING SEVERAL HEAT PUMPS ON A SKID	21
7.1 Scope of delivery	21
7.2 Technical data	21
7.3 Hydraulic installation	24
7.3.1 General installation instructions	24
7.3.2 Positioning the system	24
7.3.3 Hydraulic connections	26
7.3.4 Gas connections	30
7.3.5 Connecting the condensate drain pipe	30
7.4 Electrical connections and control - general	31
7.4.1 Connecting to the main power supply	31

7.4.2	Connecting the secondary circuit pump	33
7.4.3	Controlling the heat pumps via an On/Off signal	33
7.4.4	Wiring diagram	34
7.5	Electrical connections and control - OpenTherm	34
7.5.1	Introduction to the CAN-bus	35
7.5.2	Connecting the CAN-bus to the GEP connectors - single skid	36
7.5.3	Connecting the CAN-bus to the GEP connectors - several skids	38
7.5.4	Connecting the CAN-bus to the CAN-OT interfaces	39
7.5.5	LED signals for CAN-OT interface	41
7.5.6	Setting CAN-bus address on the heat pump	41
7.5.7	Connecting the Remeha OpenTherm controller	42
7.5.8	Connecting a water circulation pump	42
7.5.9	Controlling the heat pumps via a 0-10 V signal	42
7.6	Connection options for the 0-10 V control PCB (IF-01)	43
7.6.1	Connection status (Nc)	43
7.6.2	Connection (OTm)	43
7.6.3	Analogue input (0-10 V)	43
7.6.4	Analogue control based on temperature (°C)	43
7.6.5	Analogue control based on heat output (%)	43
7.6.6	Analogue output (0-10 V)	44
8	COMMISSIONING AND LEGISLATION	45
8.1	Introduction	45
8.2	Regulations and application	45
8.3	Points to consider regarding the configuration	45
8.3.1	General	45
8.3.2	Outside configuration	46
8.3.3	Version and scope of delivery of heat pump	46
8.4	Points to consider when operating the system	46
8.5	Other	46
9	INSPECTION AND MAINTENANCE	47

1 INTRODUCTION

This manual is a supplement to the *Installation and service manual* for the Remeha Gas HP 35 A gas absorption heat pump. The manual contains extra information on the design, installation and maintenance of the heat pump system.



WARNING

For instructions regarding installation and use of the device, please see the installation, user and maintenance documentation supplied with the device.

1.1 Symbols

This manual uses various danger levels to draw attention to the special instructions. We do this to increase the safety of the user, to prevent problems and to ensure the technical reliability of the device.



DANGER

Risk of dangerous situations resulting in serious personal injury.



WARNING

Risk of dangerous situations resulting in minor personal injury.



CAUTION

Risk of material damage.



Please note, important information

1.2 Terms and abbreviations

- **GEP:** switch box for the appliance (marked with MAIN where necessary).
- **SWW:** domestic hot water
- **Skid:** heating unit consisting of one general switch box (GEP) and two to five individual gas absorption heat pumps that are connected to one another beforehand for gas, central heating and electricity and linked to one another by supporting beams.

1.3 Liability

1.3.1 Manufacturer's liability

Our products are manufactured in accordance with the various guidelines that apply and are therefore supplied with the CE symbol and all required documents.

Due to our permanent focus on the quality of our products, we are constantly looking for ways to improve them. We therefore retain the right to change the specifications mentioned in this document.

The manufacturer cannot be held liable in the following cases:

- Failure to observe the user instructions for the appliance.
- Overdue or inadequate maintenance of the appliance.
- Failure to observe the installation instructions for the appliance.

The manufacturer will perform the initial commissioning of the heat pump system.

1.3.2 Installer's responsibility

The installer is responsible for the installation and the initial commissioning of the appliance. The installer must observe the following instructions:

- Read and observe the instructions for the appliance found in the accompanying manuals.
- Install the device in accordance with current legislation and standards.
- Perform all necessary checks.
- Explain the installation to the user.
- If maintenance is required, alert the user to the inspection and maintenance obligations relating to the appliance.
- Hand over all manuals to the user.

1.3.3 User's responsibility

In order to guarantee optimum functioning of the installation, you must observe the following instructions:

- Read and observe the instructions for the appliance found in the accompanying manuals.
- Request the assistance of a qualified installer for the installation.
- Ask Remeha to perform initial commissioning of the appliance.
- Ask the installer to explain the installation.
- Ensure that the necessary checks and maintenance work are carried out.
- Keep the manuals in good condition and near to the appliance.

This appliance must not be used by people (and children) with a physical, sensory or mental disability, or by people with a lack of technical experience, unless they are supervised by someone who can assure their safety, or they have been instructed in the correct use of the appliance. Do not allow children to play with the appliance.

1.4 Supplementary guidelines

In addition to the legal requirements and guidelines, the supplementary guidelines in this manual must also be followed. Supplements or subsequent regulations and guidelines that are valid at the time of installation shall apply to all regulations and guidelines specified in this manual.

2 SAFETY INSTRUCTIONS AND RECOMMENDATIONS

2.1 Safety instructions



DANGER

If you smell gas:

1. Do not use naked flames, do not smoke and do not operate electrical contacts or switches (doorbell, lighting, motor, lift etc).
2. Shut off the gas supply.
3. Trace possible leaks and seal them off immediately.
4. If the leak is upstream of the gas meter, notify the gas company.



DANGER

If you smell flue gases:

1. Turn off the device.
2. Trace possible leaks and seal them off immediately.



DANGER

The heat pump has a closed cooling circuit with an ammonia/water mixture under overpressure:

1. Avoid contact with skin and do not inhale or swallow the ammonia mixture.
2. Do not carry out any work on the closed cooling circuit or on the valves.



DANGER

If you smell ammonia:

1. Turn off the device.
2. Keep your distance and avoid inhaling ammonia fumes.
3. Do not carry out any work on the closed cooling circuit yourself, but leave this to a qualified installer.

2.2 Recommendations



WARNING

- Installation and maintenance of the appliance must be carried out by a qualified installer in accordance with local and national regulations.
- When performing work on the appliance, always disconnect it from the power supply and close the main gas valve.
- Check the entire system for leaks after maintenance and servicing work.

Casing panels

Casing panels may only be removed for maintenance and servicing purposes. Refit all panels when maintenance work and servicing are complete.

3 TECHNICAL DESCRIPTION

The technical data for the heat pump can be found in the *Installation and service manual* for the heat pump.

4 THERMAL DESIGN

Gas absorption heat pumps are very efficient heating appliances, but it is essential that they are integrated correctly in the heating system in order to obtain maximum output. The thermal characteristics of the system need to be designed correctly in order to achieve maximum efficiency of the heat pumps.

4.1 Control design

- A continuous on/off cycle (hunting) has a significant adverse impact on total seasonal efficiency. If the system has a low thermal capacity on the user side, adding a buffer vessel will considerably increase total seasonal efficiency.
- The efficiency of the heat pumps is increased when the outgoing water temperature is decreased.
- The system must be designed so that the return temperature is kept as low as possible, for example by using modulating system pumps (the heat pump switches off if the maximum return temperature is exceeded).

4.2 Hydraulic design

- The choice between the HT and LT versions of the heat pump depends on the type and design of the distribution system (underfloor heating, ventilation units, radiators etc). The HT version has a maximum return temperature of 55°C (65°C flow), while the LT version has a maximum of 45°C (55°C flow). Only the LT version is suitable for prolonged operation at return temperatures below 25°C.
- When the design return temperature of the system is lower than 55°C, back-up boilers are not needed for low outside temperatures. The output ratio between the heat pumps and the extra boilers can be determined based on the limiting investment on the one hand and the average efficiencies on the other.
- When the design return temperature of the system is higher than 55°C, back-up boilers are needed for low outside temperatures. The output of these boilers (excluding the heat pump output) must be sufficient for the system's heat demand at the design temperature.
- The system's design flow temperature can be selected above the maximum temperature of the heat pump when the extra boilers are hydraulically connected to the heat pumps in series (see also Fig. 02 and Fig. 03).
- The gas absorption heat pump is not the most suitable method of producing domestic hot water. The heat pump can be used, however, to pre-heat domestic hot water where a more complex and more expensive hydraulic design is acceptable.
- The outer section of the system can be filled with a glycol mixture to protect the heat exchanger from freezing. Unfortunately, the temperature difference across the heat exchanger will lower the efficiency of the heat pump.



CAUTION

It is important for both the central heating boilers and the heat pumps that the configuration of the heat transfer element is part of the hydraulic design, since efficiency increases if the system is set correctly for both the hydraulics and controls.

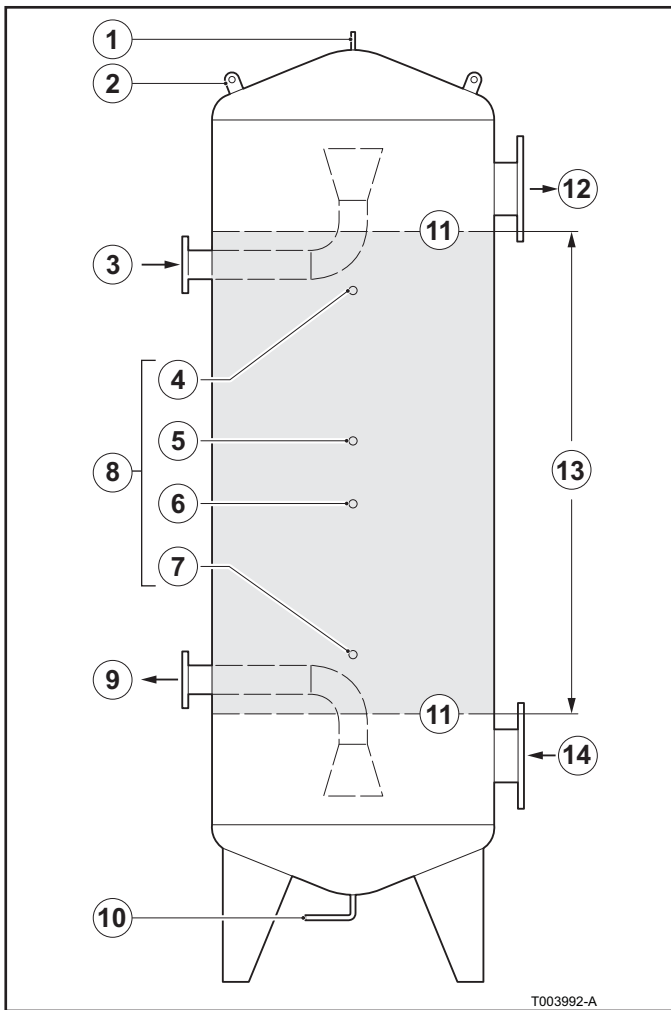

Fig. 01 Schematic drawing of the buffer vessel

4.2.1 Buffer vessel

A buffer vessel is not specifically required. If the system does not have sufficient capacity, a buffer vessel can be built into the system. The buffer vessel acts as a thermal energy battery, reducing the number of starts for the heat pumps. Too many starts in a short period of time reduce the average efficiency of the heat pumps.

The volume of the buffer vessel (in litres) can be found in the table below.

Number of Gas HP units	Effective volume* of buffer vessel in l
1	300
2	500
3	800
4	1000
5	1000

* Effective volume = volume between flow and return connections on the buffer vessel

Table 01 Buffer vessel volume

Legend

- 1 Air vent
- 2 Lifting eye
- 3 Heat pump flow
- 4 Temperature recorder
- 5 Temperature recorder
- 6 Temperature recorder
- 7 Temperature recorder
- 8 Temperature recorders
- 9 Heat pump return
- 10 Draining outlet
- 11 Separation plate (perforated)
- 12 Central heating system flow
- 13 Effective volume
- 14 Central heating system return

4.3 Hydraulic diagrams

The following examples only give a broad outline of the principle of heat production.



CAUTION

It is important for both the central heating boilers and the heat pumps that the configuration of the heat transfer element is part of the hydraulic design, since efficiency increases if the system is set correctly for both the hydraulics and controls.

Remeha Gas HP 35 A (LT/HT)

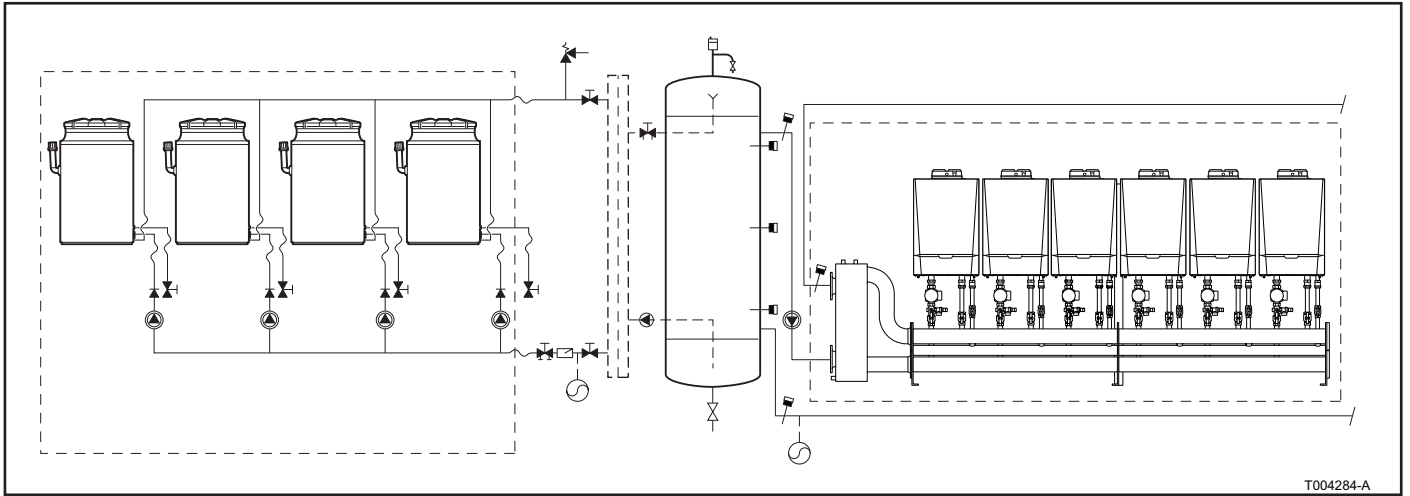

Fig. 02 Hydraulic diagram with Quinta Pro boilers

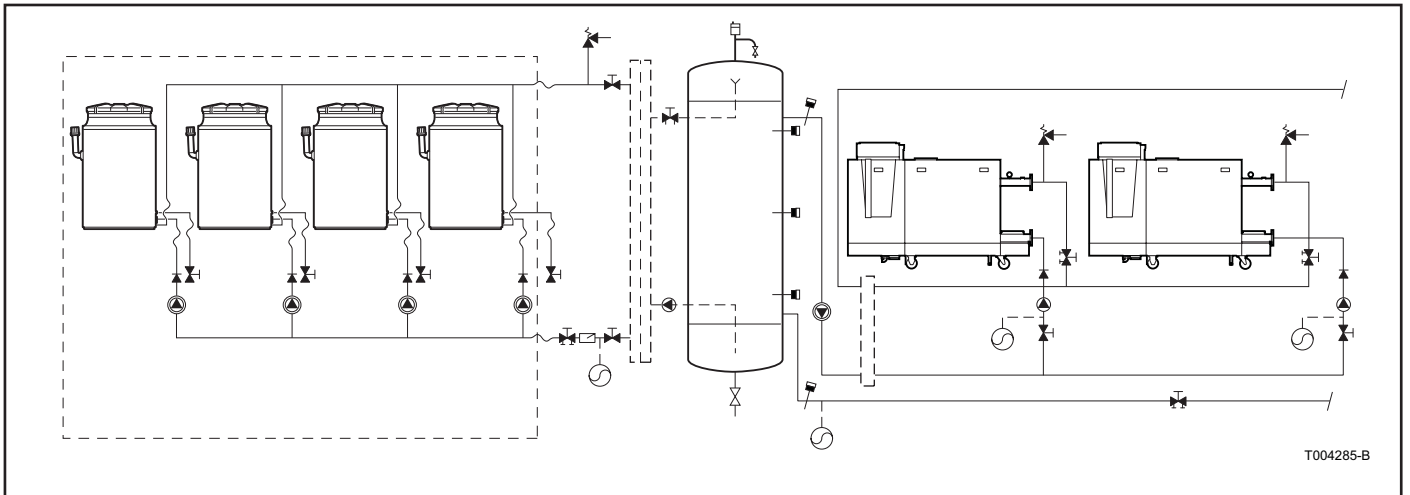

Fig. 03 Hydraulic diagram with Gas 310 boilers

5 GENERAL INSTALLATION

5.1 Installation instructions



WARNING

The appliance must be installed by a qualified installer in accordance with local and national regulations.

5.2 Important points to consider

- The temperature curve for the heat production section must be within the range of the heat pumps (over a long period).
- The buffer vessel must not be brought up to temperature regularly by groups heated to high temperatures where the temperature curve greatly exceeds the temperature curve for the heat pumps, such as a boiler group. This means that these groups must not be present or must be disconnected.
- The heat pumps must be supported on the main supporting structure. It is advisable to consult a structural engineer about this. The structural engineer can also advise on how to prevent contact noise to the homes involved. To ensure there is sufficient rigidity, both the supporting beams and stands under the frame must be at least HEB 160. The profile can be heavier if this is indicated by the load capacity calculation. This depends on the model.
- The heat pumps must be connected with flexible connections. This applies to both the gas pipe and the central heating pipes.
- The heat pumps can be controlled on and off or modulated with a 0-10 signal (option). OpenTherm control is possible under certain conditions. Contact our Sales Support department about this.
- If filler other than a glycol mixture is used, the installer himself must provide (better) insulation and an electric frost protection cable. This also includes the pipe work supplied with the skid.
- The pipe work on the accompanying skid has limited insulation; it is up to the installer to provide better insulation.
- Evaluation of the complete hydraulic system and corresponding control engineering should be part of the inventory. In order to achieve the desired savings and efficiencies, the system must be configured correctly for both the hydraulics and controls.
- Proper monitoring must to be carried out to monitor the above point. This includes regular evaluation of the temperature curve and release of the heat-producing components (heat pumps and boilers). A low supply water temperature has a positive effect on the operating time of the heat pump. A low return water temperature has the same effect and increases efficiency.

5.3 Noise and vibrations

5.3.1 Noise

Noise production of Remeha Gas HP heat pumps

Principles relating to the numbers in *Table 02*:

- This refers to a point source of sound, placed on a reflective surface, as considered from the front.
- The amount of nuisance for the surrounding area is also determined by the installation site. This means the distance and any vertical outer walls in the vicinity will be of influence.

Remeha Gas HP 35 A (LT/HT)

	Distance	Gas HP 35 A
Noise capacity		73 dB(A)
Noise pressure	5 m	51 dB(A)
	6 m	49 dB(A)
	7 m	48 dB(A)
	8 m	47 dB(A)
	9 m	46 dB(A)
	10 m	45 dB(A)
	11 m	44 dB(A)
	12 m	43 dB(A)
	13 m	43 dB(A)
	14 m	42 dB(A)
	15 m	41 dB(A)

Table 02 Noise pollution related to the distance from the heat pump (1 unit)

Positioning the heat pumps

Preferably install the heat pump on the roof and maintain the following distances, if possible:

- At least 4 m from the roof edge to prevent downward radiation.
- At least 1.5 m away from any rising outer wall to avoid amplification of the noise through reflection.

A noise specialist can determine whether the noise pressure complies with the norms for factors such as the outer walls of adjacent homes or at the edges of the property line. Additional noise reduction measures can be taken, if necessary, such as the installation of noise barriers.

5.3.2 Vibrations

- The heat pumps must be supported on the main supporting structure. Ask a structural engineer for advice. He will also be able to give advice on how to prevent structure-borne noise being carried to any living areas.
- Vibration dampers must be fitted between the heat pumps and the support construction. Standard dampers are available as an option. Any customised work must be carried out in consultation with a (noise) expert. The underlying structure must be sufficiently rigid.
- The heat pumps must be connected with flexible anti-vibration connections. This applies to both the gas and central heating pipes.

5.4 Frost protection

- Every heat pump has an antifreeze function that can be activated; see the *Installation and service manual* for the heat pump.
- The extra frost protection measures for a heat pump system on a skid are explained in *section 7.3.3*.
- The use of glycol is dealt with in detail in chapter 4.5 of the *Installation and service manual*.

5.4.1 Defrosting cycle

If the heat pump is operating with outside temperatures at around freezing point or below, the water vapour from the intake air can freeze on the evaporator fins.

If the automatic antifreeze function is activated, the heat pump will continue to supply heat to the system and start

up a defrosting cycle. This means that the evaporation and condensation process does not need to be reversed.

During the defrosting cycle, some of the ammonia flow is fed from the generator (with a temperature of approx. 80°C) directly to the evaporator, quickly getting rid of ice on the evaporator. In the meantime, the main ammonia flow continues to supply heat to the central heating water.

Experience has shown that no more than 50 defrosting cycles are needed during a normal winter. A cycle only lasts an average of 3 minutes thanks to the high condensation temperature of the ammonia flow. As a result, the defrosting cycle has no measurable effect on the efficiency of the Remeha heat pump.

5.5 Water treatment

See the *Installation and service manual* for the heat pump.

6 INSTALLING A SINGLE HEAT PUMP

The installation of the heat pump is described in the accompanying *Installation and service manual*. This chapter provides additional information about possible connections.

6.1 Scope of delivery

See the *Installation and service manual* for the heat pump.

6.2 Hydraulic installation

6.2.1 Hydraulic connections

See the *Installation and service manual* for the heat pump.

6.2.2 Gas connections

See the *Installation and service manual* for the heat pump.

6.2.3 Connecting the condensate drain pipe

See the *Installation and service manual* for the heat pump.

6.3 Electrical connections and control - general

6.3.1 Connecting to the main power supply

See chapter 5 of the *Installation and service manual* for the heat pump.

6.3.2 Controlling the heat pumps via a 0-10 V signal

The heat pumps can be controlled via a 0-10 V signal, which allows the pumps to be modulated between 50 and 100% output. Each unit is connected separately to a 0-10 V signal. The 0-10 V control is an expansion of the OpenTherm control. An OT-0-10V interface must be connected to each CAN-OT interface. This OT-0-10V interface is available as an accessory and must be built into a switch box (to be supplied by a third party). See section 7.5.9 for an explanation of how the interface works.

6.3.3 Controlling the heat pumps via an On/Off signal

The heat pumps can be controlled via one On/Off signal per unit. See the *Installation and service manual* for the heat pump for the correct connections

6.3.4 Connecting a water circulation pump

Each heat pump unit can control its own circulation pump. See the *Installation and service manual* for the heat pump for the connections.

If a Rematic MC controller is used in a system with several heat pumps, a secondary circulation pump (230 V, max. 400 VA) can be controlled on/off.

6.4 Electrical connections and control - OpenTherm

This section describes the connection of one or more heat pumps on a CAN-OT interface. For specific information about how to use and program a Remeha OpenTherm controller, see the accompanying manuals.

The Remeha Gas HP heat pump and the Remeha OpenTherm controllers communicate via the CAN-OT connection. Each heat pump requires one CAN-OT interface that needs to be built into a switch box supplied by a third party.

The CAN-bus is a network of Gas HP heat pumps and CAN-OT interfaces, called nodes, that are connected via a protected 3-wire cable. The network can have two types of nodes:

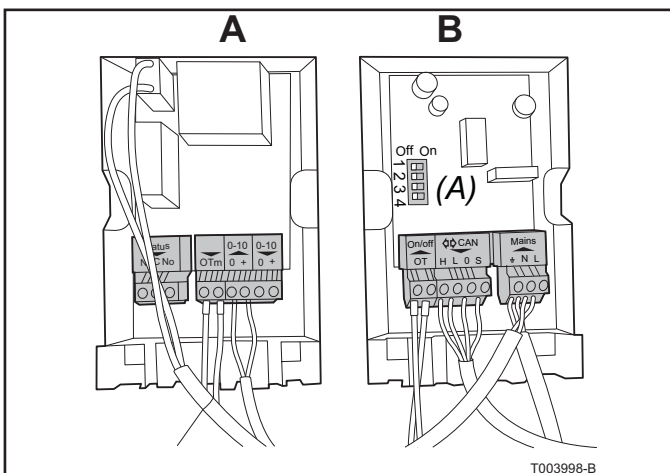

Fig. 04 OT-0-10V interface (A) and CAN-OT interface (B) without cover plate

1. End nodes
2. Intermediate nodes

There are two ways to create the CAN-bus:

- Two nodes on the CAN-bus, one CAN-OT interface and one heat pump, see Fig. 05 (A).
- Several nodes on the CAN-bus, several CAN-OT interfaces and several heat pumps, see Fig. 05 (B)



CAUTION

The OpenTherm bus only allows point-to-point connections.

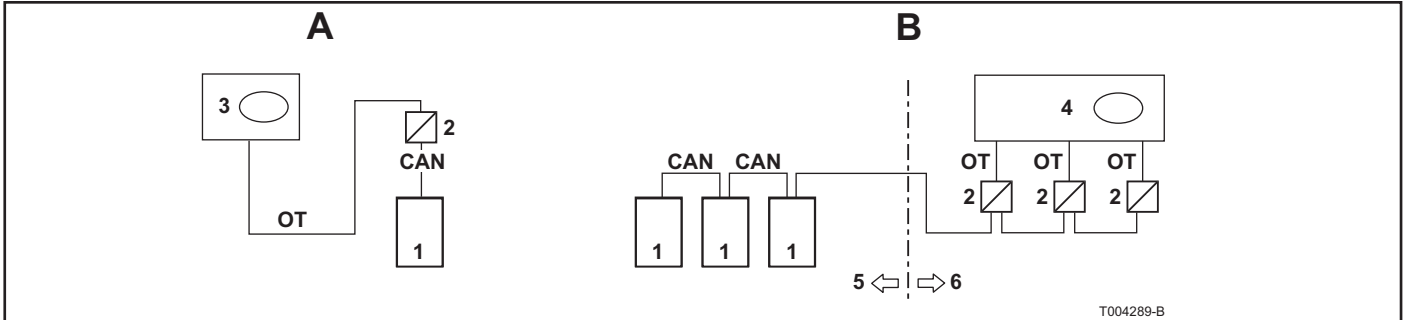

T004289-B

Fig. 05 CAN-bus with two nodes (A) and several nodes (B)

Legend

- 1 Heat pump
- 2 CAN-OT interface
- 3 OT controller
- 4 OT cascade controller
- 5 Outside
- 6 Inside

6.4.1 Introduction to the CAN-bus

The CAN-bus cable must comply with the Honeywell SDS standard. The table below shows details for a number of CAN-bus cable types, grouped according to the maximum distance for each cable type.

CABLE NAME	SIGNAL/COLOUR*			MAX. LENGTH
Honeywell SDS 1620 standard				
BELDEN 3086A	H = BLACK	L = WHITE	GND = BROWN	450 m
TURCK type 530				
DevideNet Mid Cable				
TURCK type 5711	H = BLUE	L = WHITE	GND = BROWN	450 m
Honeywell SDS 2022 standard				
TURCK type 531	H = BLUE	L = WHITE	GND = BROWN	200 m

* In all cases: do not use the fourth wire.

Table 03 CAN-bus cable types

For total distances ≤ 200 m and networks with a maximum of six nodes (e.g. three heat pumps and three CAN-OT interfaces), a single, protected 3 x 0.75 mm cable is sufficient.

The CAN-connection requires a CAN-bus cable with three wires. If the available cable has more than three coloured wires, use the wires with the colours as specified in the table and cut the other, superfluous wires off.

The entire length of the CAN-bus cable must be protected with a casing that meets the following requirements:

- Nominal diameter 17 mm
- T-section

Remeha Gas HP 35 A (LT/HT)

- Operating temperature 105°C
- Flame retardant
- Resistant to acid, oil, solvents and fuels

The TEAFLEX PAS T 17S casing meets these requirements.

6.4.2 Connecting the CAN-bus to the Gas HP heat pump

The CAN-bus cable must be connected to the special connector that is located on the internal control unit for the heat pump.

Legend

- A Insulation tape to protect the controller
- B CAN-bus cable casing (pre-wired from the penultimate heat pump)
- C Bracket to secure the CAN-bus cable
- D Connector to connect the CAN-bus cables (see Fig. 07 and Fig. 08)
- E Wires (3) for the CAN-bus cable
- F Bracket to secure the CAN-bus cable to the next heat pump (intermediate node)

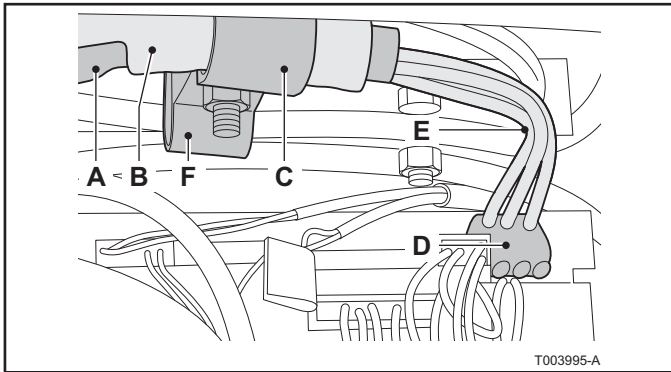

Fig. 06 CAN-bus cable connection (end node) on the printed circuit board for the Gas HP heat pump



WARNING

Make sure the heat pump has been disconnected from the power supply before starting work on the electrical panel.

1. Cut off a piece of cable that is long enough for the connection without any loops forming.
2. Remove approximately 70-80 mm of the cable casing and the wires within it. Make sure you do not damage the shield.
3. If the cable used is too thin to be secured in the cable bracket (see C in Fig. 06), thicken the cable by wrapping insulation tape around the cable casing next to the stripped section (up to a diameter of approx. 12-13 mm).
4. Pull the shield back over the cable casing and use insulation tape to fasten the end of the shield that has been pulled back (see Fig. 06 (A)).
5. If the heat pump is an end node in the network, connect the three coloured wires to the orange connector as shown for D in Fig. 06. Connect the correct colours to the L, H and GND connections as indicated in Table 03 and Fig. 07.
6. If the heat pump is an intermediate node, repeat steps 2 to 5 for a different piece of cable so that two cables are available with the cable casing removed at one end. Always plait the two wires with the same colour together and then connect them to the orange connector as shown for D in Fig. 06 and in Fig. 08.
7. Use the cable bracket to secure the CAN-bus cable(s) to the top part of the inside of the electrical panel in such a way that the cable casing that is folded back is in close contact with the metal bracket (see Fig. 06 C and F). The bracket must keep the cables in place firmly when the cables are pulled.

The jumper settings on the control unit depend on the node type:

- A. If the Gas HP heat pump is an end node in the network (three wires connected to the orange connector on the control unit), set the jumper as illustrated in *Fig. 07*.
- B. If the Gas HP heat pump is an intermediate node in the network (six wires connected to the orange connector on the control unit), set the jumper as illustrated for devices 1 and 2 in *Fig. 08*.

6.4.3 Connecting the CAN-bus to the CAN-OT interface - two nodes

Legend

GND	Common data
L	LOW data signal
H	HIGH data signal
O	Zero
S	SHIELD (protection)

The CAN-bus cable is connected to the special yellow/green **HL0S** connector that is fitted in the X2 connector of the CAN-OT interface.

WARNING

Make sure the heat pump has been disconnected from the power supply before starting work on the electrical panel.

1. Open the CAN-OT interface from above by pressing the top of the cover and carefully pulling it forward.
2. The jumpers on the CAN-OT interface must be set as indicated in *Fig. 07*. The CAN/OT interface is an end node.
3. Cut off a piece of cable that is long enough for the connection without any loops forming.
4. Remove approximately 20 mm of the cable casing and the wires within it. Make sure you do not cut into the cable protection (plaited metal or aluminium foil and, if present, the bare connection in contact with the plait).
5. Disconnect the cable connector from connection **HL0S** on connector **X2**.
6. Connect the cable's shield to connection **S** on connector **X2**.
7. Connect the cable to connector **X2** as indicated in *Fig. 07*. Pay attention to the marks on the connector where **GND** needs to be connected to **O**.
8. Refasten the cable connector on **X2**.

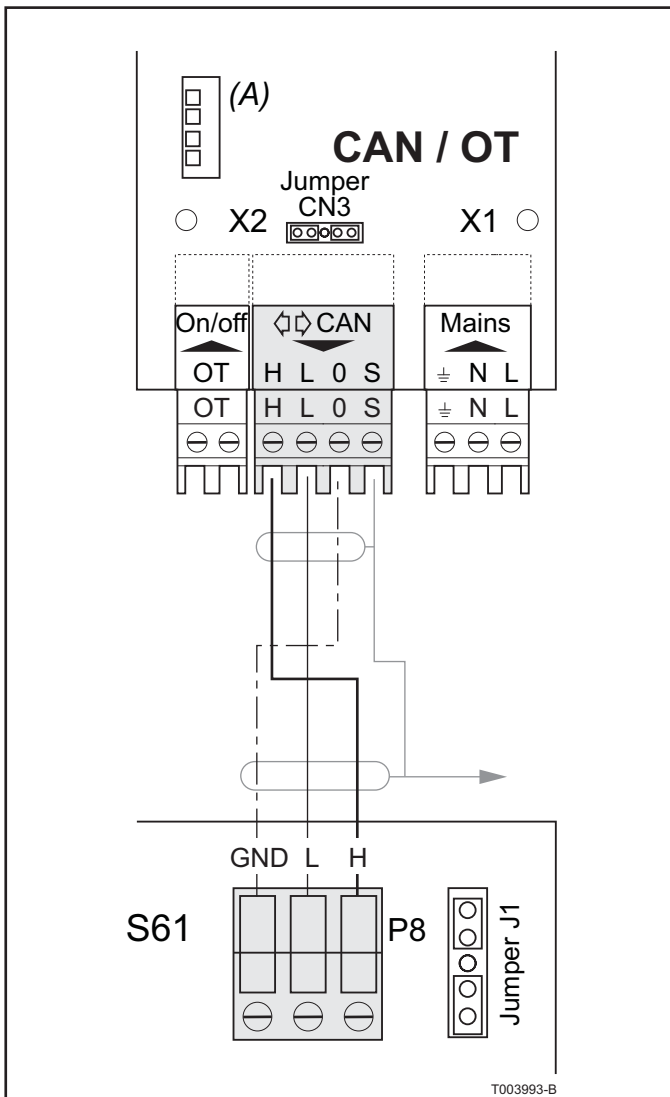

Fig. 07 Connections on the CAN-OpenTherm interface and Gas HP printed circuit board (two nodes)

Remeha Gas HP 35 A (LT/HT)

6.4.4 Connecting the CAN-bus to the CAN-OT interface - several nodes

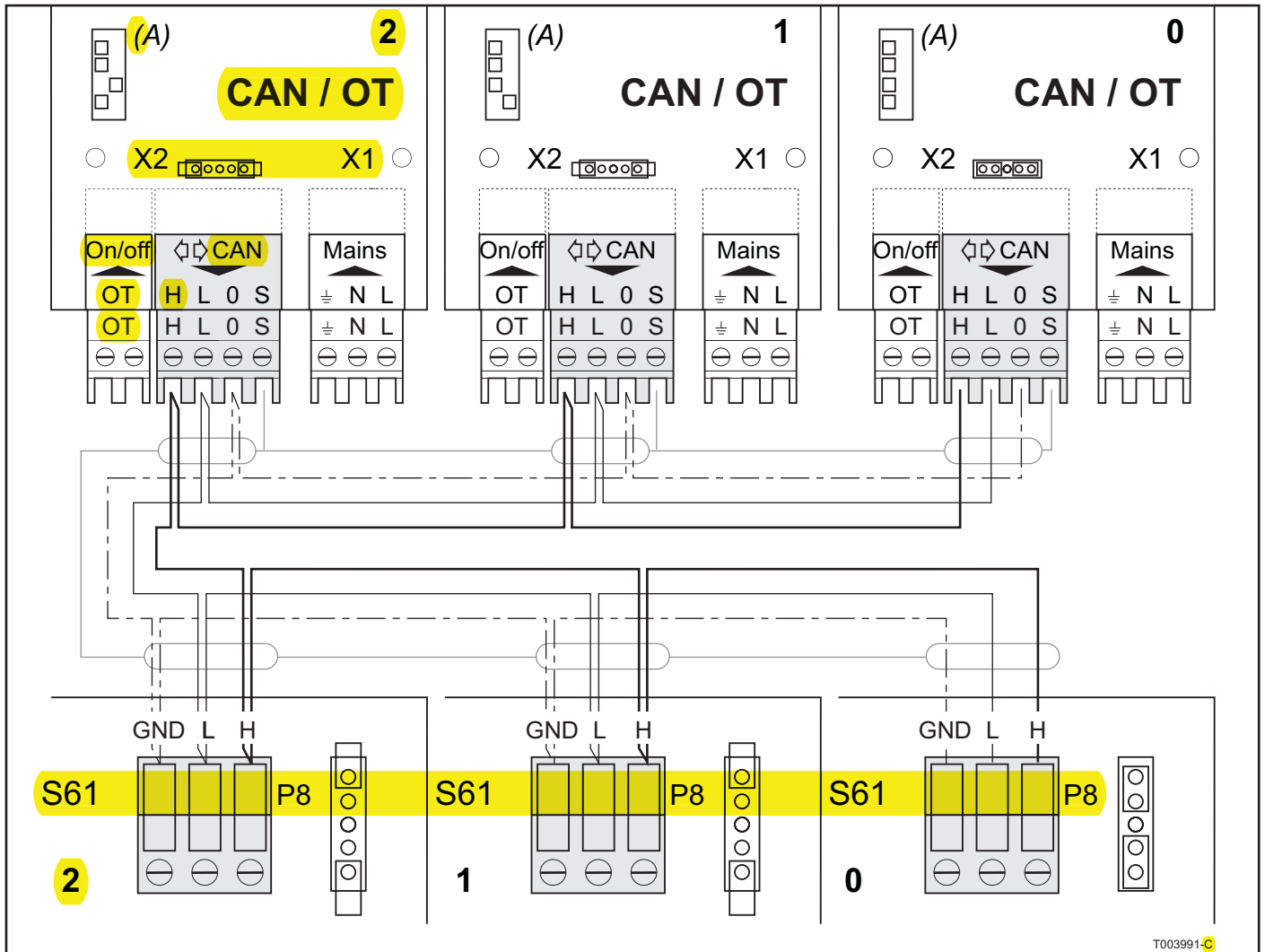

Fig. 08 Connections on the CAN-OpenTherm interface and Gas HP printed circuit board (several nodes)

Legend

S61	Heat pump printed circuit board
CAN/OT	CAN/OT interface
J1	CAN-bus jumper
CN3	CAN-bus jumper
A	Addressing jumper interface
P8	CAN-connector
CAN	CAN-connector

CAN-OT interfaces 1 + 2 and heat pumps 1 + 2 are intermediate nodes

CAN-OT interface 0 and heat pump 0 are end nodes

The following table indicates which jumpers need to be configured together with the address in the device.

Unit address	Jumper 1 position	Jumper 2 position	Jumper 3 position	Jumper 4 position
0	OFF	OFF	OFF	OFF
1	OFF	OFF	OFF	ON
2	OFF	OFF	ON	OFF
3	OFF	OFF	ON	ON
4	OFF	ON	OFF	OFF
5	OFF	ON	OFF	ON
6	OFF	ON	ON	OFF
7	OFF	ON	ON	ON
8	ON	OFF	OFF	OFF
9	ON	OFF	OFF	ON
10	ON	OFF	ON	OFF
11	ON	OFF	ON	ON
12	ON	ON	OFF	OFF
13	ON	ON	OFF	ON
14	ON	ON	ON	OFF
15	ON	ON	ON	ON

Table 04 Address table

6.4.5 LED signals for CAN-OT interface

If several faults occur simultaneously, the LED signalling will display each fault in order of priority, until the problem is resolved. The following list shows the order of priority. LED status 0 has the highest priority.

LED on	No errors OpenTherm and CAN-bus communication working
LED flashes	2x: No OpenTherm communication 3x: No CAN-bus communication 4x: Incorrect CAN-bus address settings 5x: Internal error 6x: CAN device is not supported
LED off	No voltage Faulty

Table 05 LED signals for CAN-OT interface

6.4.6 Setting CAN-bus address on the Gas HP heat pump

In order to operate several heat pumps in a CAN-bus network combined with CAN-OT interfaces, each heat pump must be allocated a clear code. This can be done by setting parameter 40 in menu 5 for the heat pumps.

Parameter 40 is the printed circuit code and identifies the device in the CAN network. Each heat pump is given a unique code, independent of its position in the system. The value that needs to be set for parameter 40 is the numerical code assigned to the device and can vary from 0 to 478.

Set parameter 40 as follows:

1. Remove the front casing of the heat pump by unscrewing and removing the screws.
2. Remove the cover plate of the electrical panel to be able to access the set-up button.

Remeha Gas HP 35 A (LT/HT)

3. Insert the supplied key in the set-up button to access the control menus and the parameters.
4. Press the button once to display the available menus; the display shows the first menu as "0" (menu 0).
5. Rotate the button clockwise to display the other menus; the display then shows "1", "2", "3", "4", "5", "6", "7", "8" and "E".
6. Rotate the button to menu 5 to set the CAN-bus address. Press the button to make a selection or to confirm.
7. Use access code 2222 to access menu 5. Rotate the button to 2 and press to confirm. Repeat this until you have entered the full access code.
8. Rotate the button to parameter 40 and press to confirm. Now enter the CAN-bus address for the heat pump. Rotate the button to the number to be entered and press to confirm. Repeat this action until the complete address has been entered.
9. Go to menu E and press the button to leave the control menus.
10. Replace the cover plate for the switch box and the front casing.

6.4.7 Connecting the Remeha OpenTherm controller

Use two-wire cables to connect each CAN-OT interface to the OpenTherm (cascade) controller. A simple 2 x 0.5 mm unprotected cable can be used. OpenTherm is not susceptible to polarity, so the wires can be swapped.

7 INSTALLING SEVERAL HEAT PUMPS ON A SKID

This chapter describes the installation of a group of heat pumps on a skid. See the *Installation and service manual* for the Gas HP heat pump for the commissioning, gas changes, service and maintenance of the heat pumps.

7.1 Scope of delivery

- Frame consisting of thermally galvanised steel beams.
- Stainless steel main pipes and distribution manifolds, insulated by an insulation cover with an aluminium finish.
- Galvanised steel gas pipes
- Flexible couplings for connecting the individual heat pumps to the manifolds
- Independent modulating circulation pump (per heat pump)
- External switch box with automatic fuses
- Central condensate drain with internal trace heating

See the *Installation and service manual* for the technical specifications, control and safety components of the heat pumps.

7.2 Technical data

Installation data		Unit	Data per skid			
Number of Gas HP pumps	n.		2	3	4	5
Output (A7/W50)	kW		70	105	140	175
Load (Hi)	kW		51.4	77.1	102.8	128.5
Gas consumption (G25)	m ³ /h		6.32	9.48	12.64	15.80
Nominal rate of flow (ΔT 10 K)	m ³ /h		6	9	12	15
Residual lift (ΔT 10 K)	kPa		20			
Water content	l		15.5	23.7	32.2	41.5
Supply voltage (voltage, type - frequency)			230 V - 50 Hz or 400 V 3 + N - 50 Hz	400 V 3 + N - 50 Hz		
Max. electricity consumption	W		2640	3960	5280	6600
Electrical protection index			IP X5D			
Gas connection \varnothing ⁽²⁾	"		1 ½" F			
Water connection (flow/return) \varnothing ⁽²⁾	"		2" M			
Condensate drain \varnothing ⁽²⁾	"		1" F			
Noise level (max.) at 10 m ⁽³⁾	dB(A)		50	52	53	54
Dimensions	Width	mm	2320	3610	4940	6490
	Depth	mm	1245			
	Height	mm	1650			
Weight	kg		970	1425	1920	2395

⁽²⁾ For details, see Fig. 17 and Fig. 18
⁽³⁾ Free field, frontal

Table 06 Technical data for Remeha Gas HP 35 A units on a skid

Remeha Gas HP 35 A (LT/HT)

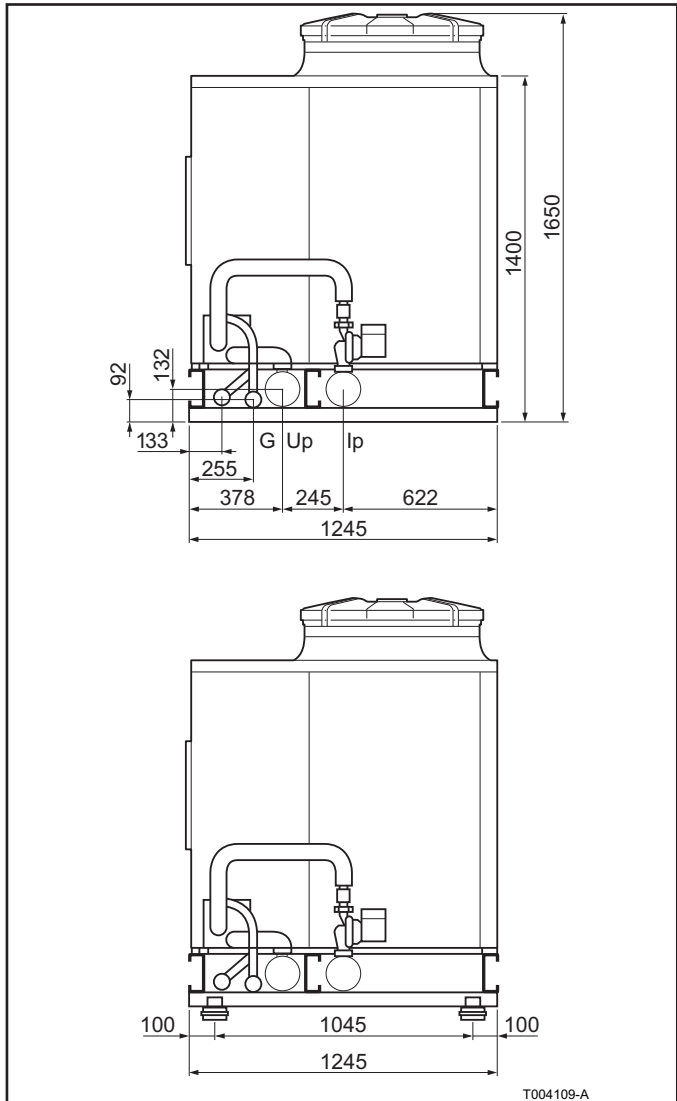

Fig. 09 Connection side of the configuration, with mounting points for the vibration dampers

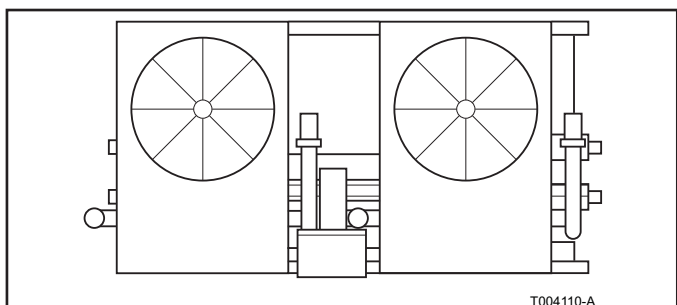

Fig. 10 Top of the configuration with two heat pumps

- Legend:**
- C = Condensate drain 1" (clamp-mounted)
 - G = Gas connection 1 1/2"
 - Up = Flow 2"
 - Ip = Return 2"

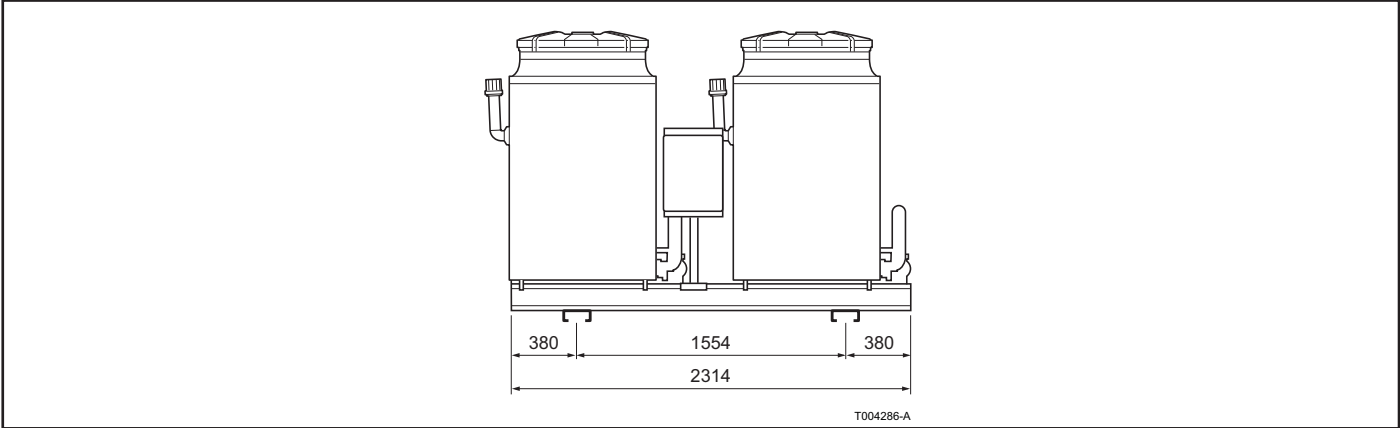

Fig. 11 Front of the configuration with two heat pumps

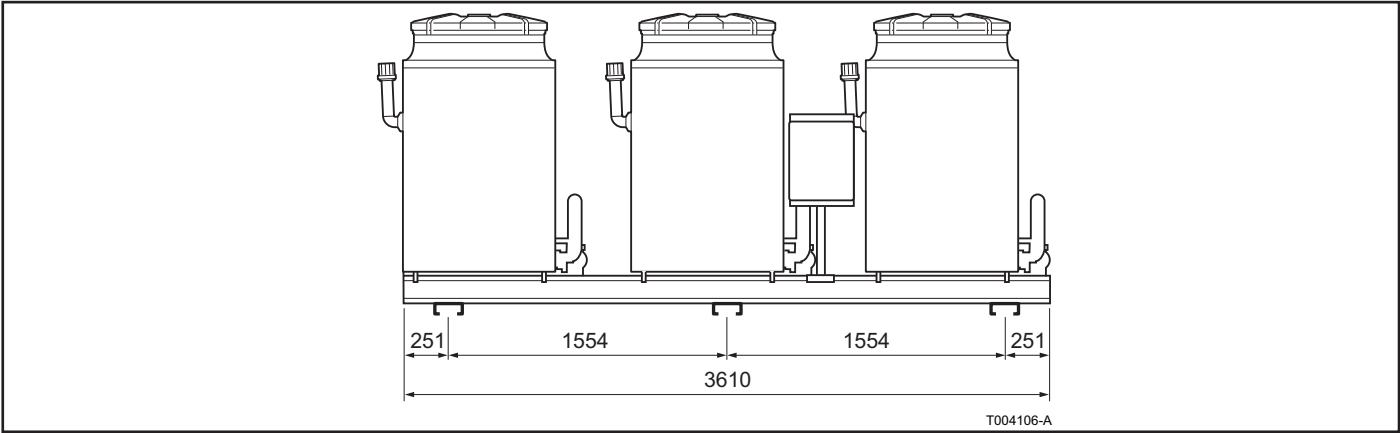

Fig. 12 Front of the configuration with three heat pumps

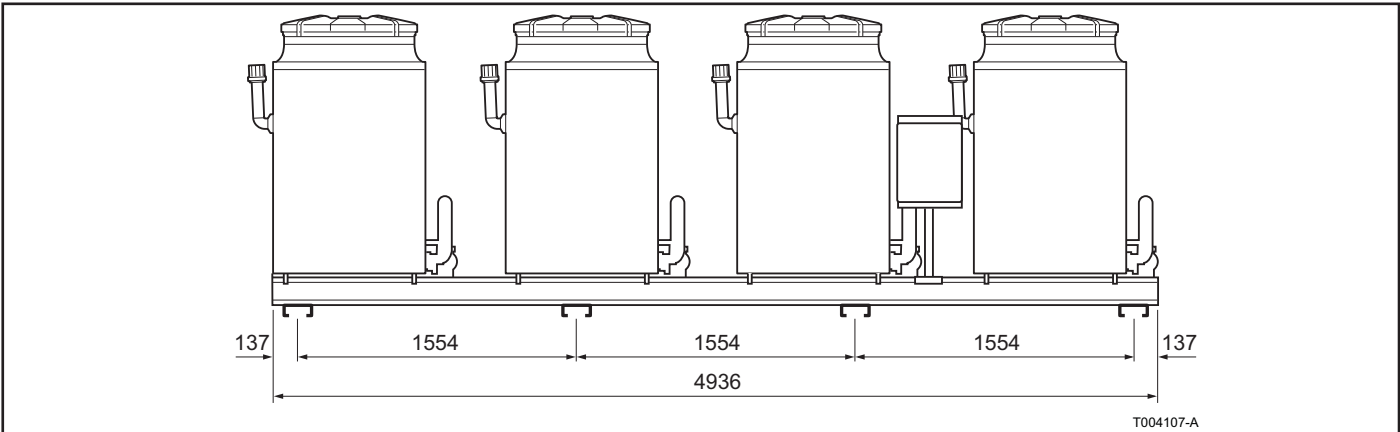

Fig. 13 Front of the configuration with four heat pumps

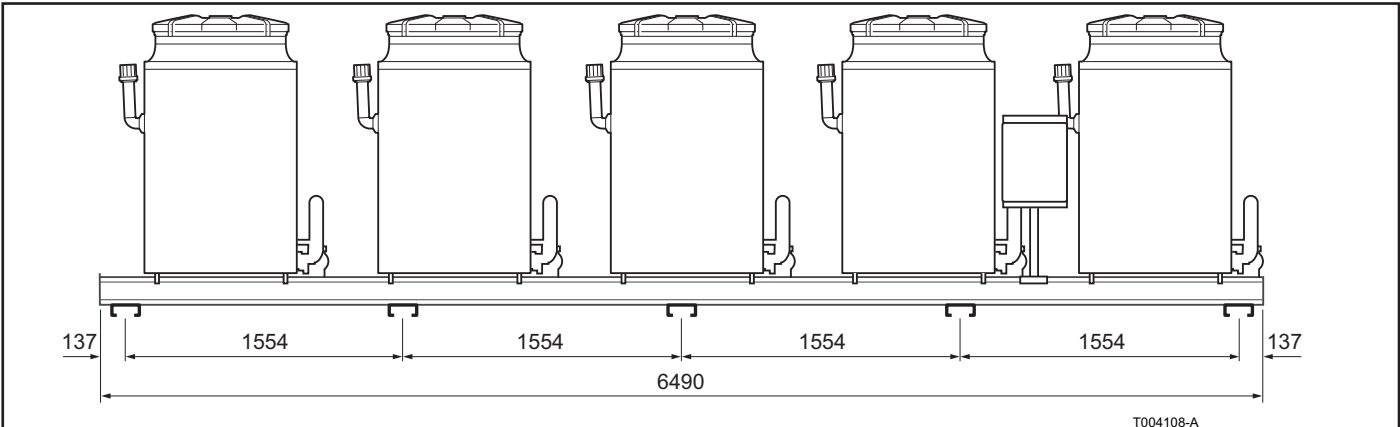

Fig. 14 Front of the configuration with five heat pumps

Remeha Gas HP 35 A (LT/HT)

7.3 Hydraulic installation

7.3.1 General installation instructions

- Thoroughly clean the inside of all pipes and all parts to be used in the system before starting the installation.
- Check whether the gas supply complies with the specifications of the system's manufacturer. See the accompanying manuals.
- The system must be installed on the outside of the building, in an area with natural air circulation and sufficient protection from the weather.
- The system can be installed on the ground floor or on a terrace or roof, if the terrace or roof is suitable for the size and weight of the system.



WARNING

The system must not be installed in a closed room.



CAUTION

The system must be installed in an area that is always accessible.

- The fan discharge opening at the top of the appliance must not be obstructed or covered by overhanging constructions (protruding roofs, roof edges, balconies, ledges or trees).
- Do not place the system in the immediate vicinity of gas outlets, chimneys or similar objects, in order to prevent hot or polluted air from being sucked in by the fan.
- If the system has to be installed near other buildings, make sure there is no risk of water leaking onto it from dripping gutters etc.
- A gas cock and flexible coupling are needed to connect the gas supply.
- Use flexible connections (anti-vibration connecting pieces) between the heat pump system and the hydraulic and gas supply pipes.
- See the *Installation and service manual* for the heat pump for specific instructions regarding the installation of the heat pump.

7.3.2 Positioning the system

Lifting instructions

The heat pump system must remain in its original packaging during positioning.



CAUTION

Only remove the factory packaging once the system is definitely in place.

If the system needs to be lifted, secure two hoisting belts or cables to the openings provided at the bottom of the system. Use spacer bars to prevent the cables from damaging the panels during lifting when the system is moved. (See Fig. 15).

WARNING

- The crane and all required accessories (belts, cables, bars etc.) must be strong enough for the load to be lifted.
- The manufacturer cannot be held liable for any damage that occurs during the positioning and installation of the heat pump system.

See *section 7.2* for the system's weight

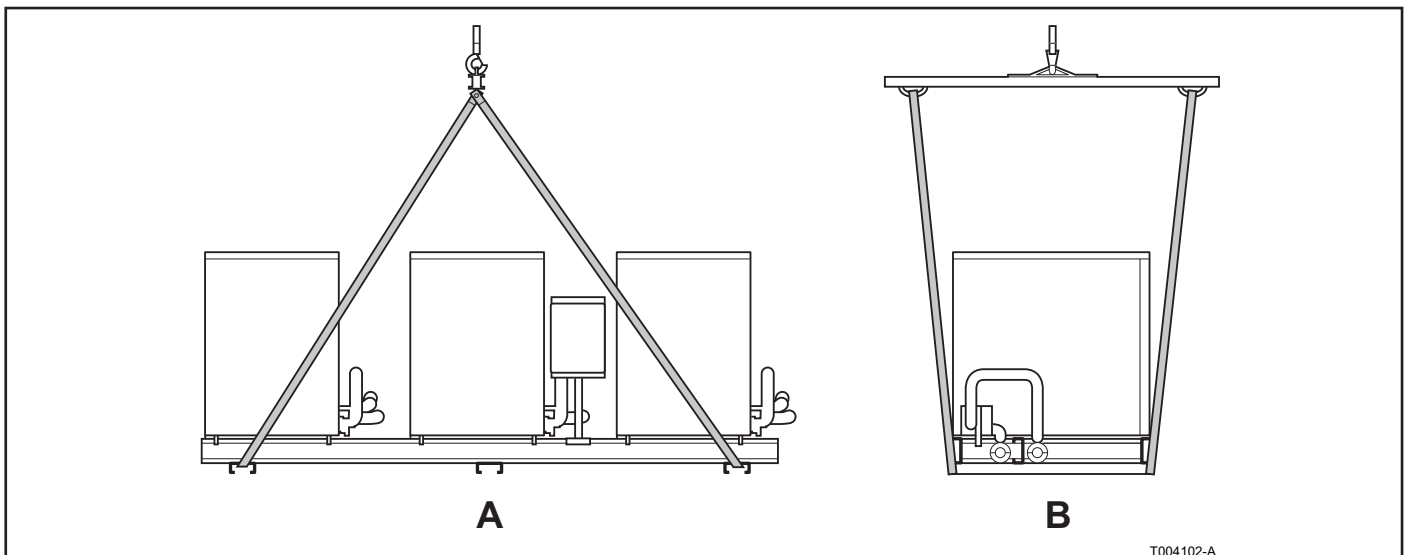

Fig. 15 Moving the system

Legend

- A Front view
- B Side view

Surface

CAUTION

Place the system level on a flat, horizontal surface made from fire-resistant material that is suitable for supporting the system's weight.

Installation on the ground floor

If no horizontal surface is available, a flat concrete base must be created that is at least 100-150 mm larger on all sides than the dimensions of the bottom of the heat pump system. See *section 7.2* for the system's dimensions.

Installation on a terrace or roof

The structure of the building must be able to support the weight of the heat pump system and the supporting base. See *section 7.2* for the system's weight.

Do not position the heat pump system directly above rooms where silence is required, such as bedrooms, meeting rooms etc.

Support and levelling

The heat pump system must be levelled using a spirit level on the top part of the system. If necessary, the system can be levelled using metal shim plates. Take the system's support legs into account when inserting the shim plates. The skid

Remeha Gas HP 35 A (LT/HT)

must be secured (separated acoustically) to the lower frame to provide sufficient resistance to the weather.



CAUTION

Do not use wooden shims as these are quickly affected by moisture.

Free space

Position the heat pump system so that there is sufficient distance from combustible surfaces, walls or other appliances. Maintain the minimum distance as indicated in *Fig. 16*.

A minimum amount of free space is needed in order to perform maintenance on the system and to guarantee sufficient air supply for the fans in the heat pumps. Create a gangway around the system, if necessary.

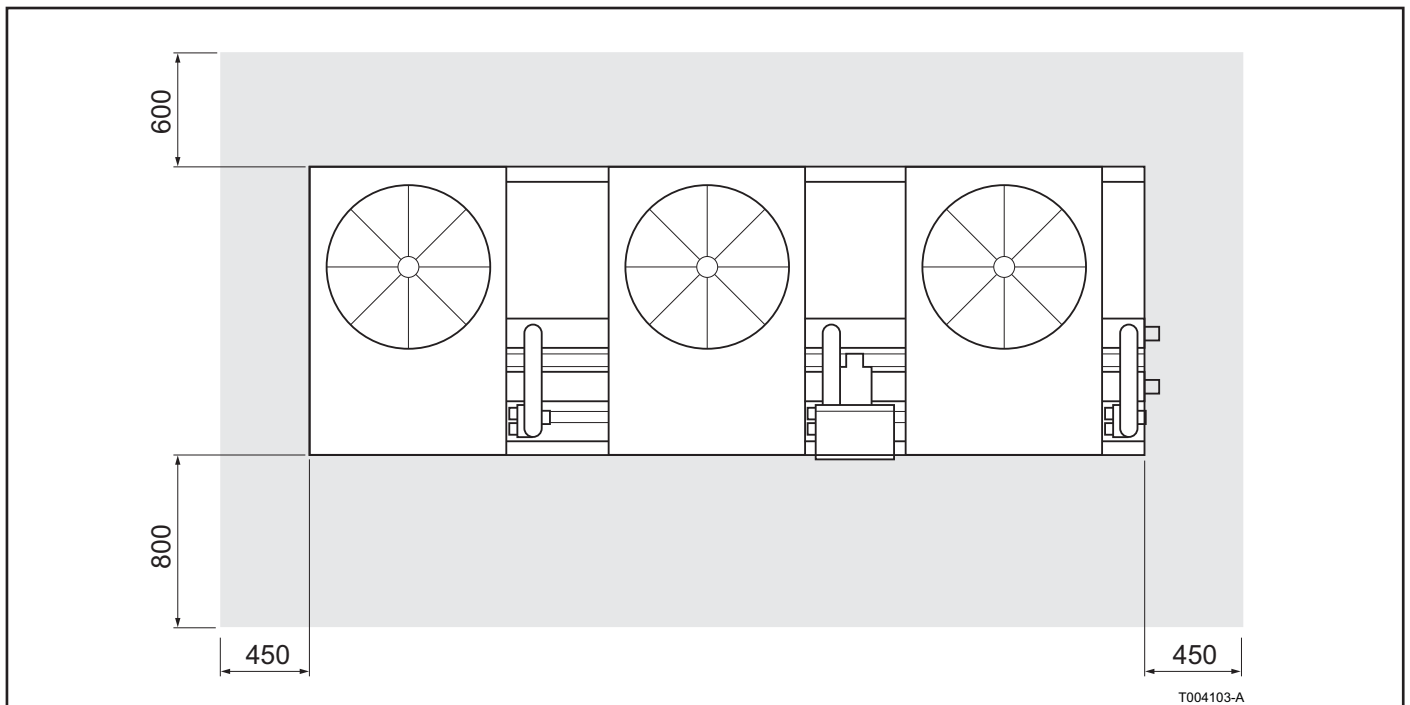

Fig. 16 Minimum amount of free space around the heat pump system

7.3.3 Hydraulic connections

General guidelines

- Use pipes made from stainless steel, steel, copper or cross-linked polyethylene that is suitable for this purpose. All water pipes and connections must be sufficiently insulated, in accordance with current standards, in order to prevent loss of heat and the development of condensation.



WARNING

Do not use galvanised pipes or connections when using a glycol mixture as the antifreeze agent. This is because of the risk of corrosion.

- Use anti-vibration connecting pieces to prevent vibrations when rigid pipes are used for the system's water supply and discharge.

- See the *Installation and service manual* for the heat pump for the required water quality.

Frost protection

To limit the risk of the system freezing, the heat pumps are equipped with an antifreeze function. When the antifreeze function is activated, the external water circulation pump and, if necessary, the correct burner will be started.

See the *Installation and service manual* for the heat pump on how to switch on the antifreeze function.

It is important to ensure there is a continuous supply of gas and electricity to the system during the entire winter period. If a continuous supply cannot be guaranteed, the following measures must be taken:

1. Fit all the outdoor pipe work (including the part delivered with the skid) with a suitable frost protection cable system and improved insulation. The frost protection cable system can, preferably, be fitted with its own separate power supply.
2. Use monoethylene glycol as an antifreeze. See *Installation and service manual* for the required glycol quality. When using antifreeze, you will need to install an extra plate heat exchanger between the outer and inner parts of the system. Even using an oversized heat exchanger may result in extra loss of efficiency due to the extra temperature step in the heat exchange. The dimensions of the pipes and the pump must be adequate for a nominal water flow that is sufficient for the system to function correctly. Take into account the internal pressure drop in the system.



CAUTION

- A glycol and water mixture has a different viscosity and heat capacity from water.
- The glycol and water mixture needs to be checked and replaced periodically.

Fig. 17 and Fig. 18 show the hydraulic fittings needed to connect one or more heat pumps.

Remeha Gas HP 35 A (LT/HT)

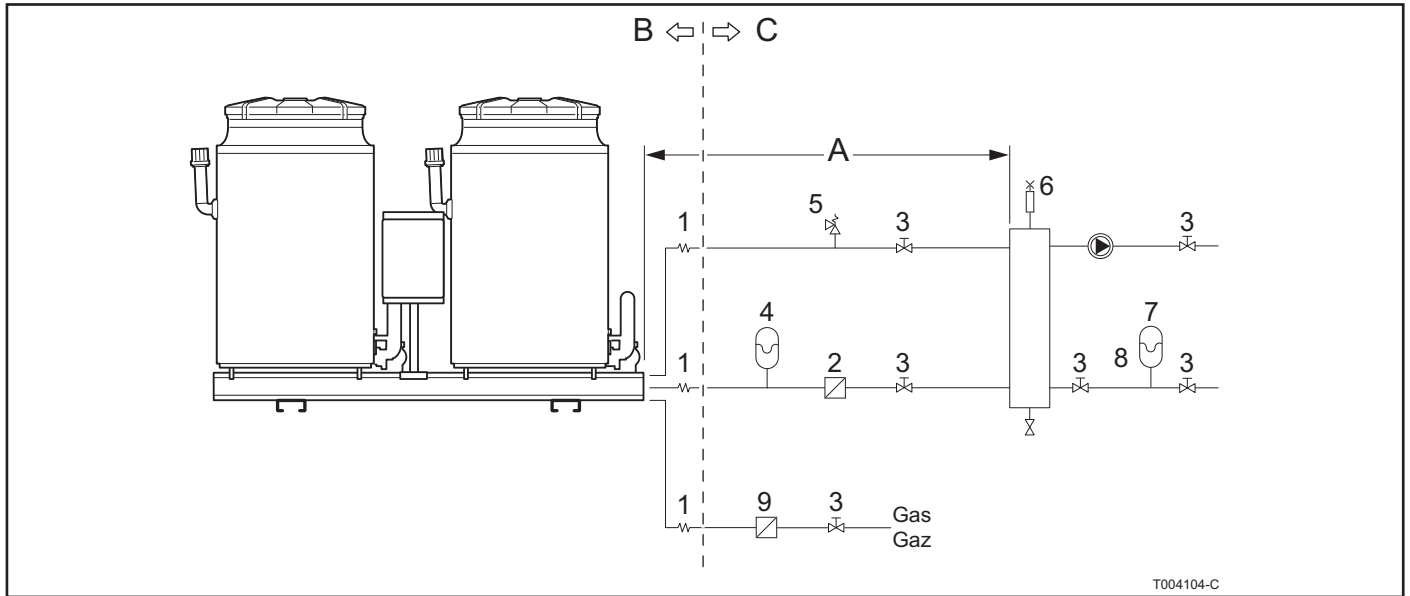

Fig. 17 Hydraulic connection of one skid

Legend

- 1 Anti-vibration connecting pieces
- 2 Water filter (mesh min. 0.7 mm - max. 1 mm)
- 3 Shut-off valve
- 4 Expansion vessel primary circuit
- 5 Safety valve 3 bar
- 6 Hydraulic separation or buffer vessel (with vent and tap)
- 7 Expansion vessel secondary circuit
- 8 Pump secondary circuit
- 9 Controller (via interfaces)
- 10 Gas filter
- A Max. useable residual lift 20 kPa
- B Outside
- C Inside

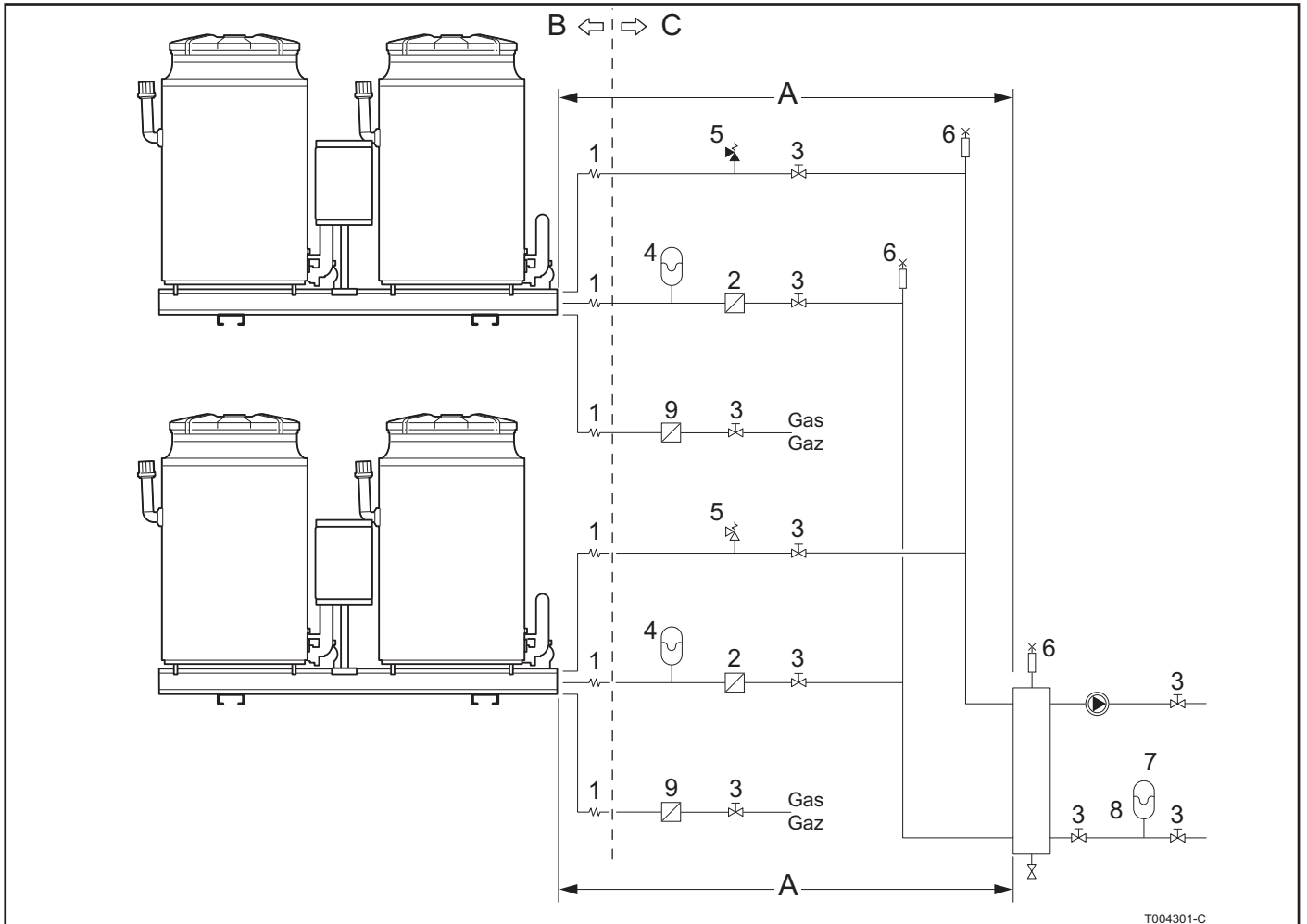

Fig. 18 Hydraulic connection of two skids

Legend

- 1 Anti-vibration connecting pieces
- 2 Water filter (mesh min. 0,7 mm - max. 1 mm)
- 3 Shut-off valve
- 4 Expansion vessel primary circuit
- 5 Safety valve 3 bar
- 6 Hydraulic separation or buffer vessel (with vent and tap)
- 7 Expansion vessel secondary circuit
- 8 Pump secondary circuit
- 9 Controller (via interfaces)
- 10 Gas filter
- A Max. useable residual lift 20 kPa
- B Outside
- C Inside

Remeha Gas HP 35 A (LT/HT)

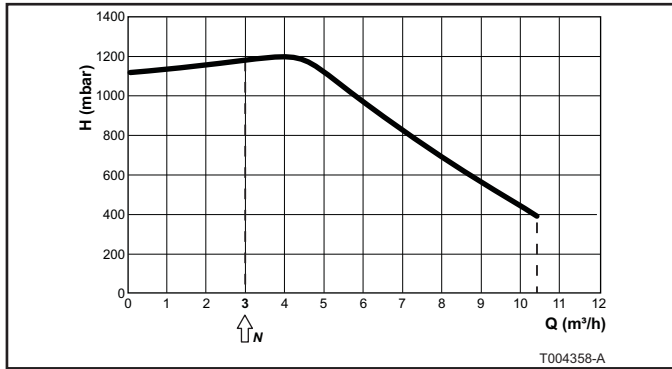

Fig. 19 Pump characteristic of the WILO Stratos Para 30/1-11 pump

Circulation pump

Legend

- H Lift
- Q Rate of water flow
- N Nominal rate of flow



CAUTION

The Wilo Stratos Para circulation pump has its own control, which can temporarily block or permanently lock the pump if there is air or pollution in the pipes. In certain situations, this can conflict with the control for the heat pump, creating a flow fault in the heat pump. If the circulation pump is locked, perform a reset by temporarily disconnecting the power supply to the pump (> 30 s).

7.3.4 Gas connections

See the *Installation and service manual* for the heat pump for the required inlet gas pressure and connection details.



WARNING

- An excessively high inlet gas pressure can damage the gas valve.
- Connect the main gas valve before starting work on the gas pipes.
- Before installing, check that the gas meter has sufficient capacity. Take into account the consumption of all appliances.
- Notify your local energy company if the gas meter has insufficient or too much capacity.



CAUTION

- The gas pipe must be connected in accordance with the applicable regulations.
- Fit a gas shut-off valve.

7.3.5 Connecting the condensate drain pipe

The main condensate pipe is on the right-hand side of the system (see Fig. 09).

Connect a condensate drain pipe to this.



CAUTION

- The pipes must be able to withstand an acidity level of pH 3-5.
- The drain pipe must slope down at least 10 mm per metre.
- Make sure the slope is correct when choosing the connection-side condensate drain.
- Condensed water must not be discharged into a gutter.
- The condensate drain pipe must be connected in accordance with the applicable regulations.

If it is not possible for the drain pipe to have the required slope, a condensate pump must be installed near the drain. Install the condensate pump so that it cannot become frozen under operating conditions. Neutralise the pH value of the condensate as much as possible, for example, by mixing it with domestic waste water with an alkaline pH (from washing machines, dishwashers etc). Do not drain the condensate via

the rain water drainage system because of the risk of freezing and possible corrosion of the materials used.

7.4 Electrical connections and control - general

7.4.1 Connecting to the main power supply

The connection to the main power supply is made inside the general switch box (GEP). The GEP is divided into three panels.

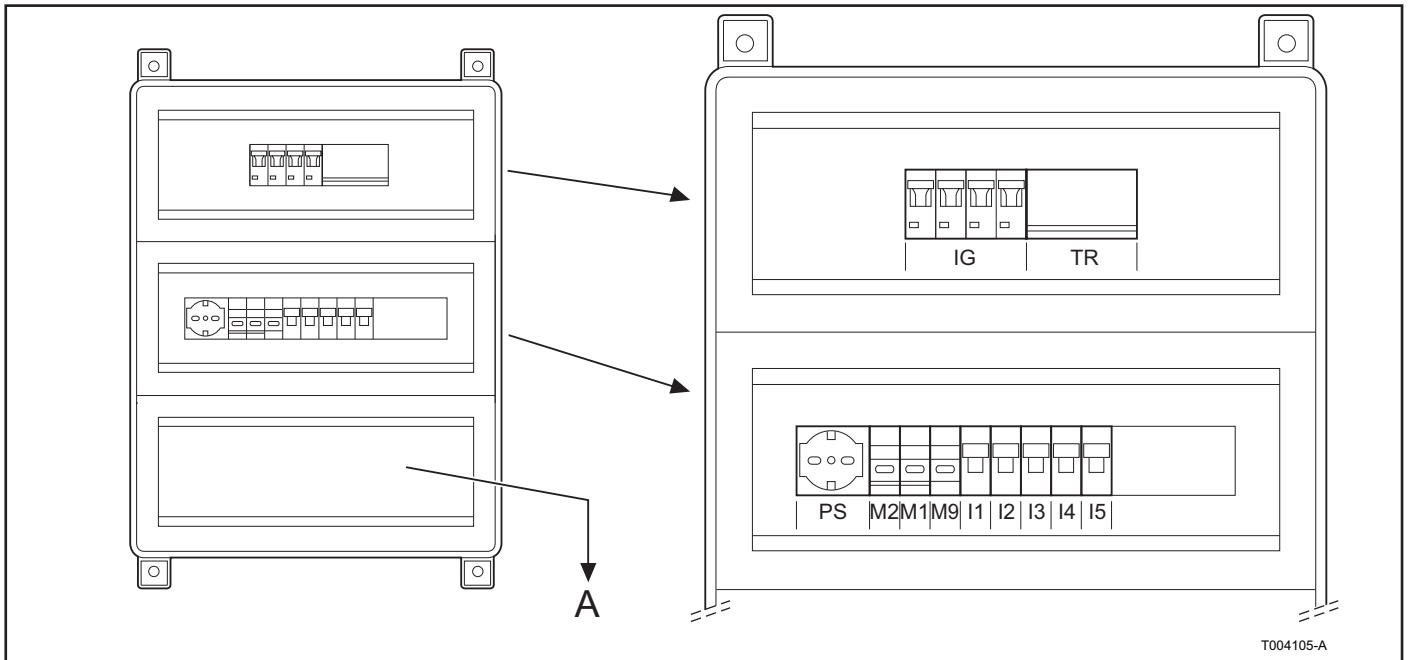

Fig. 20 The general switch box (GEP)

Legend

- IG Circuit breaker (GEP)
 - TR 230/24 V AC transformer
 - M1 Transformer main fuse
 - M2 Service power socket fuse
 - M9 Transformer secondary fuse
 - A Closed panel (see Fig. 21)
 - PS Service power socket
 - I1 Thermal circuit breaker for appliance with address 0
 - I2 Thermal circuit breaker for appliance with address 1
 - I3 Thermal circuit breaker for appliance with address 2
- Note: the order or position of the components in the GEP can differ from the drawing.

Remeha Gas HP 35 A (LT/HT)

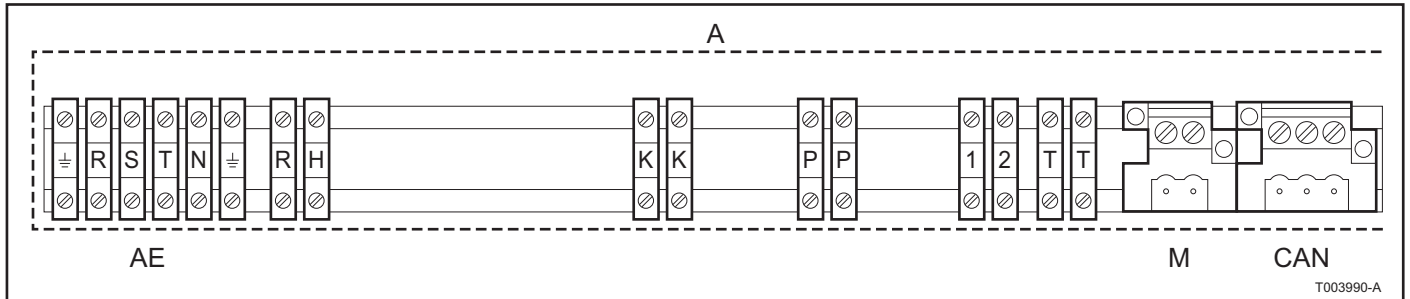

Fig. 21 Terminals in the closed panel

Legend

A GEP closed panel

AE Terminals for power supply (three-phase, earth)

RH Terminals for main condensate pipe trace heating

KK n/a

PP 24 V AV terminals for controlling circulation pump

1-2 n/a

T-T n/a

M n/a

CAN 3-pole terminal for CAN connection

Note: the order or position of the components in the GEP can differ from the drawing.

The heat pump system must be connected to a 400 3N - 50 Hz or, alternatively, a 230 V 1N - 50 Hz main power supply. Proceed as follows:

- Make sure the system is connected hydraulically and the switch box from which the power supply is drawn is prepared by an installer.
- Make sure this switch box is equipped with a 2 or 4-pole circuit breaker with a minimum contact distance of 3 mm and fitted with the right fuses.
- Open the GEP with the supplied key and remove the lower blind panel to access the terminal strips.
- Find the AE connector (with terminals R, S, T and N) and connect the 400 V 3 N - 50 HZ or 230 V 1 N - 50 Hz power supply as shown in Fig. 22 and Fig. 23 respectively.
- Close the blind panel.

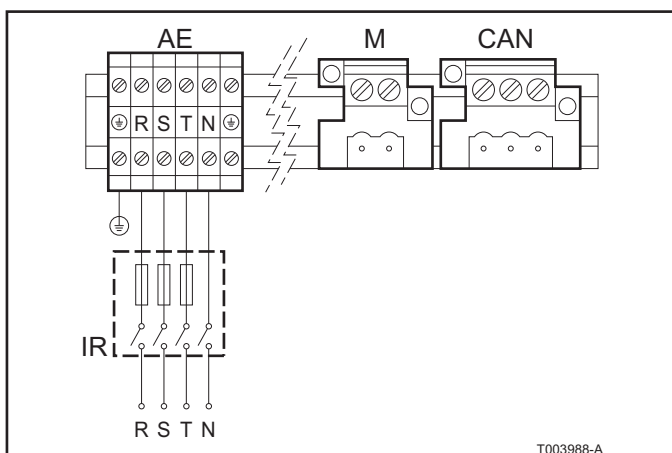

Fig. 22 Wiring diagram for the three-phase 400 V 3 N - 50 Hz system

Legend

AE Terminals for electricity (RSTN: three-phase, zero)

IR 4-pole circuit breaker with fuses

RSTN Phases/zero

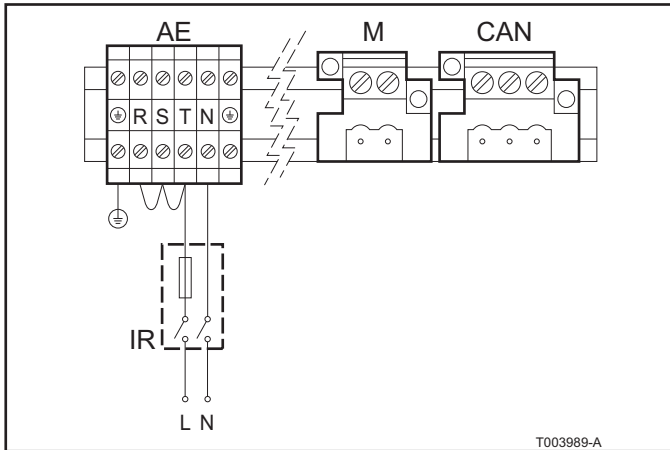

Fig. 23 Wiring diagram for the 1-phase 230 V 1 N - 50 Hz systems

Legend

AE	Terminals for electricity (LN: phase, earth)
IR	2-pole circuit breaker with fuses
RSTN	Phases/zero



CAUTION

- Installing relays or other electrical components in the general electrical panel is not permitted.
- An incorrect electrical connection or disruption to the system's proper functioning can cause damage to the system's electrical components.
- Do not switch on the heat pump if the hydraulic system has not yet been filled.
- Only use the external circuit breaker to switch off the power supply to the system after the complete shut down cycle (via the control) has been completed.
- Make sure the earth wire is longer than the phase wires. This ensures that the earth wire is the last to be pulled loose if the cables are accidentally tugged.
- Do not use any gas pipes to ground the electrical installation.

7.4.2 Connecting the secondary circuit pump

- Remeha strongly recommends regulating the speed of the secondary circuit pump so that the return temperature of the secondary circuit is always as low as possible.
- The secondary circuit pump must be controlled via the system's control (building management system).
- The electrical components needed for the connection (relays, fuses, switches etc.) must be fitted in an external switch box.
- The secondary circuit pump may be connected to the terminals of a Rematic MC. The pump can then be controlled on and off. For more information, see the documentation for the Rematic MC.

7.4.3 Controlling the heat pumps via an On/Off signal

The heat pumps can be controlled via one On/Off signal per unit. As the units on a skid are pre-wired for the CAN-bus, this cabling must be adapted by the installer. There is room in the GEP on the skid for extra connectors if the CAN-bus terminal is removed from the DIN rail. See the *Installation and service manual* for the heat pumps for the correct connections.

7.4.4 Wiring diagram

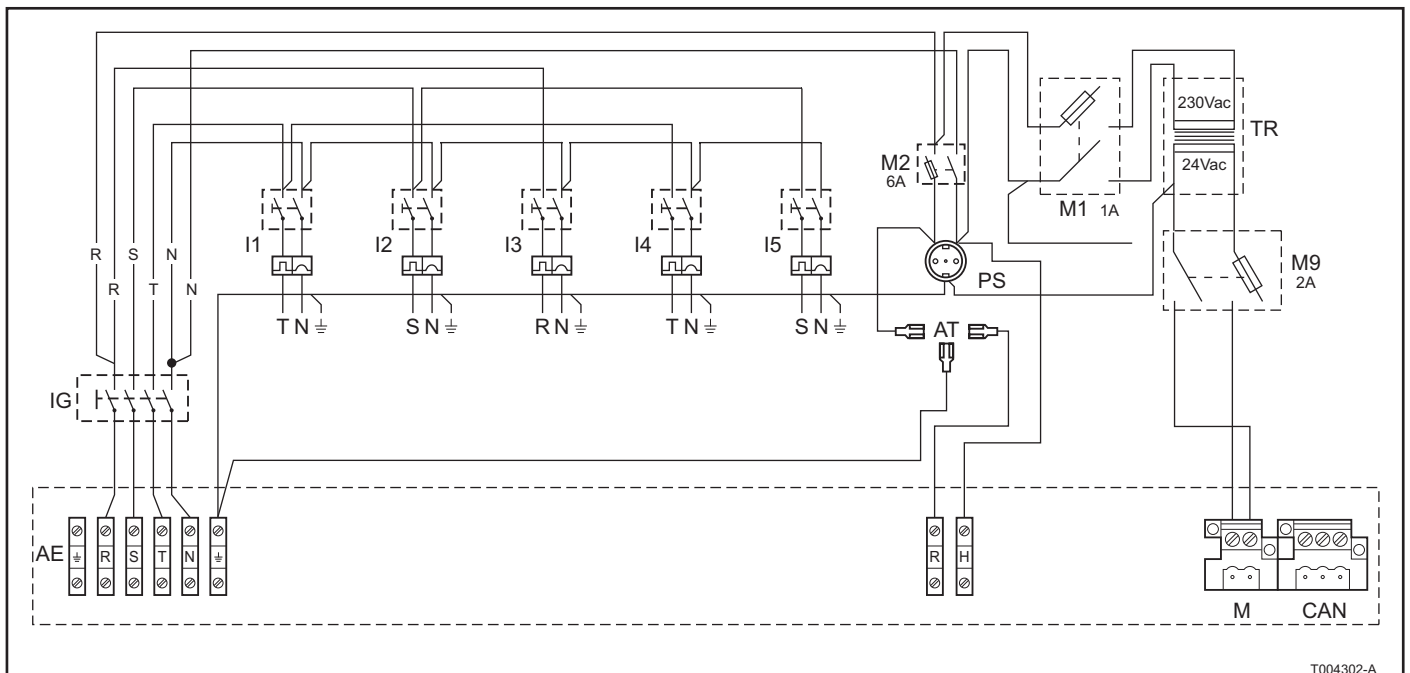

Fig. 24 Wiring diagram for skid with five heat pumps

Legend

AE	Terminals for electricity (RSTN: three-phase, earth)
IG	QEG circuit breaker
M2	Power socket fuse
PS	Power socket (230 V AC)
M1	Phase/neutral fuse
TR	230/24 V AC transformer
M9	Secondary transformer fuse
AT	Antifreeze thermostat
RH	Resistance heating

7.5 Electrical connections and control - OpenTherm

This section explains how to connect the heat pumps on the skid to the CAN-OT interface modules. Fit the CAN/OT interfaces in the boiler room, not in the unit; preferably in a switch box. This is because the CAN-bus cable can be used over a longer distance without problems than the individual OpenTherm cables. Consult the Sales Support department regarding the use of an OpenTherm controller. For specific information about how to use and program a Remeha OpenTherm controller, see the accompanying manuals.

The Gas HP heat pump and the Remeha OpenTherm controllers communicate via the CAN-OT connection. One CAN-OT interface is needed for each heat pump. This must be fitted in an external switch box.

The CAN-bus is a network of Gas HP heat pumps and CAN-OT interfaces, called nodes, that are connected via a protected 3-wire cable. The network can have two types of nodes:

1. End nodes
2. Intermediate nodes

The CAN-bus route on one skid is as follows:
 Several nodes on the CAN-bus, several CAN-OT interfaces and several heat pumps. The CAN-bus cables for the heat pumps and for the CAN-OT interfaces are connected in the general electrical panel (GEP). The maximum number of heat pumps on one skid is five (see Fig. 25).

The CAN-bus route for several skids is as follows:
 Several nodes on the CAN-bus, several CAN-OT interfaces and several heat pumps. The CAN-bus cable for the CAN-OT interfaces is connected to the first general electrical panel (GEP). The last heat pump on a skid (this is configured as an intermediate node) is connected with a CAN-bus cable to the general electrical panel for the next skid. The maximum number of heat pumps is 16. (See Fig. 26).

CAUTION
 The OpenTherm bus only allows point-to-point connections.

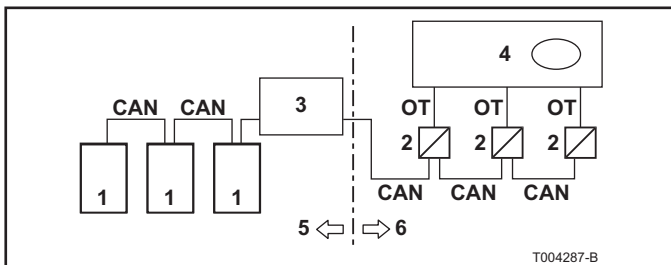

Fig. 25 CAN-bus with one skid

- Legend**
- 1 Heat pump
 - 2 CAN-OT Interface
 - 3 General switch box (GEP)
 - 4 OT cascade controller
 - 5 Outside
 - 6 Inside

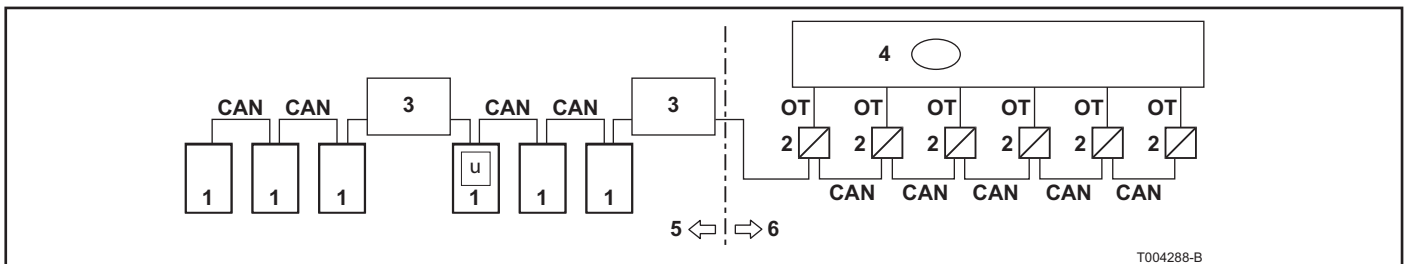

Fig. 26 CAN-bus with several skids

- Legend**
- 1 Heat pump
 - 2 CAN-OT Interface
 - 3 General switch box (GEP)
 - 4 OT cascade controller
 - 5 Outside
 - 6 Inside
 - u Unit becomes intermediate node

7.5.1 Introduction to the CAN-bus

CAUTION
 The heat pumps on the skids are already connected to the CAN-bus cable on delivery and have a CAN-bus address.

The CAN-bus cable must comply with the Honeywell SDS standard. The table below shows details for a number of CAN-bus cable types, grouped according to the maximum distance for each cable type.

Remeha Gas HP 35 A (LT/HT)

CABLE NAME	SIGNAL/COLOUR*			MAX. LENGTH
Honeywell SDS 1620 standard				
BELDEN 3086A	H = BLACK	L = WHITE	GND = BROWN	450 m
TURCK type 530				
Devidenet Mid Cable				
TURCK type 5711	H = BLUE	L = WHITE	GND = BROWN	450 m
Honeywell SDS 2022 standard				
TURCK type 531	H = BLUE	L = WHITE	GND = BROWN	200 m

* In all cases: do not use the fourth wire.

Table 07 CAN-bus cable types

- The lengths shown in the table include the pre-wired CAN-bus cable parts in the skid. The lengths of the pre-wired parts on the skid are as follows:
 - 12 m for a skid with two units
 - 18 m for a skid with three units
 - 24 m for a skid with four units
 - 30 m for a skid with five units
- For total distances ≤ 200 m and networks with a maximum of six nodes (e.g. three GAS HP units and three CAN-OpenTherm interfaces), a single, protected 3 x 0.75 mm cable is sufficient.
- The CAN-connection requires a CAN-bus cable with three wires. If the available cable has more than three coloured wires, use the wires with the colours as specified in the table and cut the other, superfluous wires off.

The entire length of the CAN-bus cable must be protected with a casing that meets the following requirements:

- Nominal diameter 17 mm
- T-section
- Max. operating temperature 105°C
- Flame retardant
- Resistant to acid, oil, solvents and fuels

The TEAFLEX PAS T 17S casing meets these requirements.

7.5.2 Connecting the CAN-bus to the GEP connectors - single skid

The CAN-bus cable must be connected to the special connectors that are located on the general switch box (GEP). Proceed as follows:



WARNING

Make sure the skid has been disconnected from the power supply before starting work on the electrical panel.

1. Open the GEP with the supplied key and remove the closed panel (A) by unscrewing the four screws (see Fig. 20).
2. Cut off a piece of cable that is long enough for the connection without any loops forming.
3. Remove approximately 70-80 mm of the cable casing and the wires within it. Make sure you do not cut into the cable protection (plaited metal or aluminium foil and, if present, the bare connection in contact with the plait).

4. If the cable used is too thin to be secured in the cable bracket (see D in Fig. 27), thicken the cable by wrapping insulation tape around the cable casing next to the stripped section (up to a diameter of approx. 12-13 mm).
5. Loosen the screws for the cable bracket slightly at the spot where the CAN-bus cable needs to be fastened (see E in Fig. 27).
6. Pull the shield back over the cable casing and fasten it to the cable bracket (see D and E in Fig. 27) through the other eye of the bracket itself (see D in Fig. 27). The bracket must keep the cable firmly in place when the cable is pulled.
7. Insulate the surplus part of the shield to prevent it from coming into contact with the printed circuit board (see C in Fig. 27).
8. Retighten the screws for the cable bracket. Make sure the appliance is earthed.
9. Connect the three coloured wires in accordance with the colour code in Table 07 to the three terminals H, L and GND for the 3-pole connector (see A in Fig. 28).

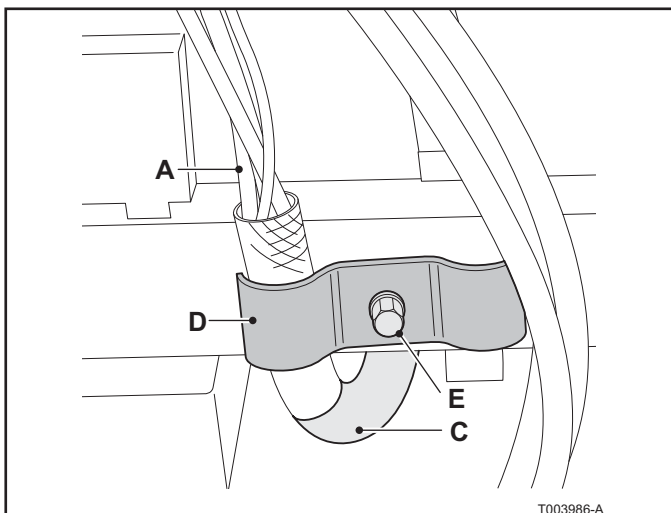

Fig. 27 CAN-bus cable connection on the GEP (rear view of the DIN rail)

Legend

- A CAN-bus cable wires to CAN connector on front of DIN rail
- C CAN-bus cable casing insulation tape
- D Cable bracket eye
- E Cable bracket screw

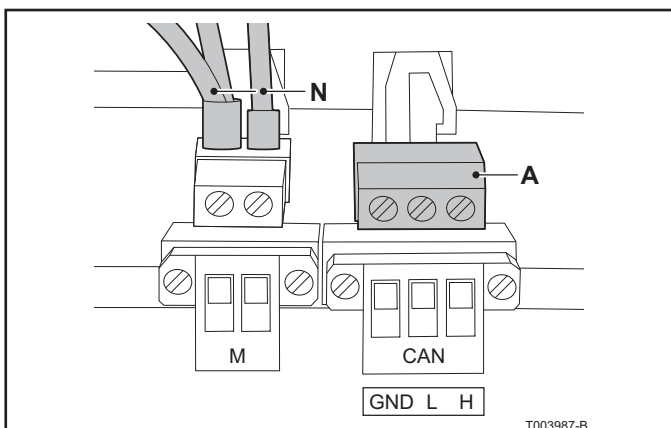

Fig. 28 CAN-bus cable connection on the GEP (front view of the DIN rail)

Legend

- CAN GND, L, H terminals (3-pole connector)
- A Pre-wired CAN-bus cable clamps
- M Terminals 1, 2 (2-pole connector)
- N Electricity wires

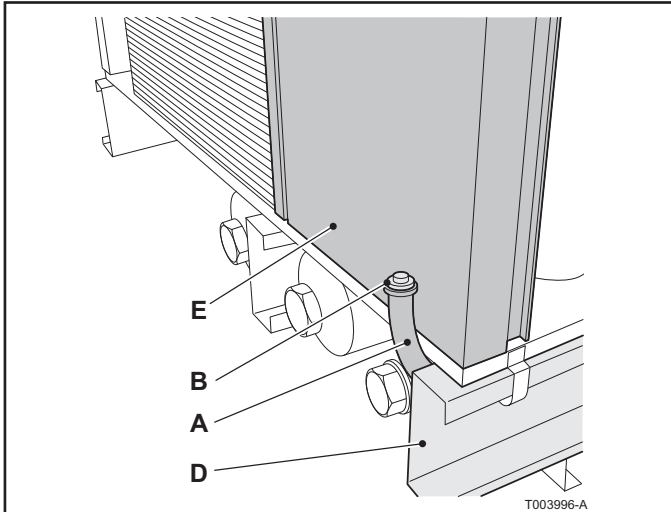

Fig. 29 CAN-bus cable casing and puller wire

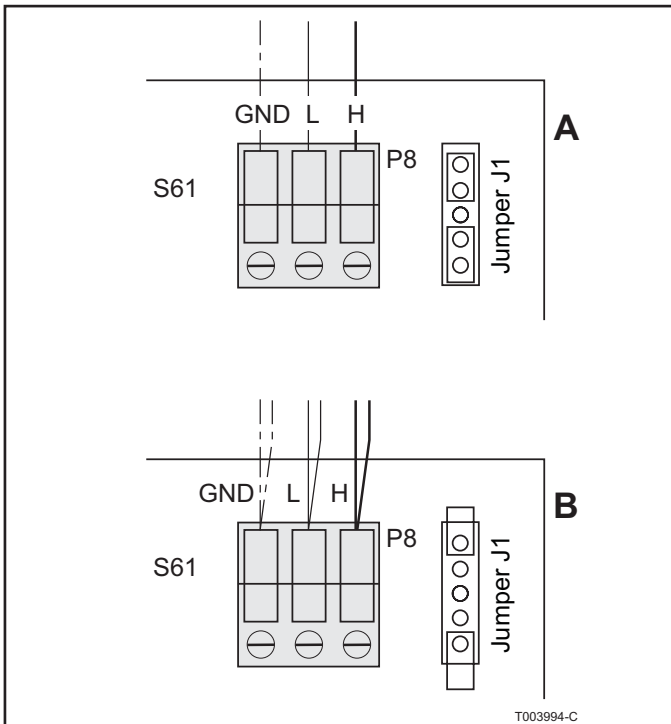

Fig. 30 CAN-bus cable connection (end node and intermediate node) on the printed circuit board of the Gas HP heat pump

7.5.3 Connecting the CAN-bus to the GEP connectors - several skids

The last heat pump on each skid is configured as an end node in the factory and is ready to be connected with a CAN-bus cable to the next skid (see Fig. 29 and Fig. 30).

Legend

- A CAN-bus cable casing
- B CAN-bus cable casing cap
- D Skid support beam
- E Last heat pump of the skid

The last heat pump on the first skid must be connected to the GEP for the next skid and is changed from an end node (see A in Fig. 30) to an intermediate node (see B in Fig. 30). Proceed as follows:

- Remove the front casing and open the electrical panel for the last heat pump on the first skid.
- Under the heat pump, behind the support beam (see E in Fig. 29), you will find the CAN-bus cable casing with cap (see A and B in Fig. 29).
- Cut off a piece of CAN-bus cable that is long enough for the connection without any loops forming.
- Open the cap of the cable casing and secure the CAN-bus cable to the puller wire located under the cap.
- Use the puller wire to pull the CAN-bus cable through until at least 50-60 cm protrudes above the other end of the cable casing.
- Remove the puller wire and secure the CAN-bus cable to the control unit as described in Section 6.4.2 "Connecting the CAN-bus to the GAS HP pump".
- Connect the other end of the CAN-bus cable to the GEP of the next skid as described in the section "Connecting the CAN-bus to the GEP connectors - single skid".
- If there are more than two skids, repeat the procedure until all the skids are connected.
- Close the electrical panel and refit the front casing for the heat pump.

7.5.4 Connecting the CAN-bus to the CAN-OT interfaces

Fit the CAN-OT interfaces in the boiler room, not in the unit; preferably in a switch box. This is because the CAN-bus cable can be used over a longer distance without problems than the individual OpenTherm cables. The CAN-bus cable is connected to the special yellow/green **HL0S** connector that is fitted in the X2 connector of the CAN-OT interface.



WARNING

Make sure the skid has been disconnected from the power supply before starting work on the electrical panel.

1. Open the CAN-OT interface from above by pressing the top of the cover and carefully pulling it forward.
2. The jumpers on the CAN-OT interface must be set as indicated in *Table 08*. The CAN/OT interface is an intermediate node or end node.
3. Cut off a piece of cable that is long enough for the connection without any loops forming.
4. Remove approximately 20 mm of the cable casing and the wires within it. Make sure you do not cut into the cable protection (plaited metal or aluminium foil and, if present, the bare connection in contact with the plait).
5. Disconnect the cable connector from connection **HL0S** on connector **X2**.
6. Connect the cable's shield to connection **S** on connector **X2**.
7. CAN/OT is an end node. Connect the cable to connector **X2** as indicated for the interface with address 0 in Fig. 31. Pay attention to the marks on the connector where **GND** needs to be connected to **0**.
8. The CAN/OT interface is an intermediate node. The **HL0S** connections will all have two wires connected; one wire for the incoming signal and one wire with the same colour for the outgoing signal (see the interfaces with addresses 1 and 2 in Fig. 31).
9. Refasten the cable connector on **X2**.

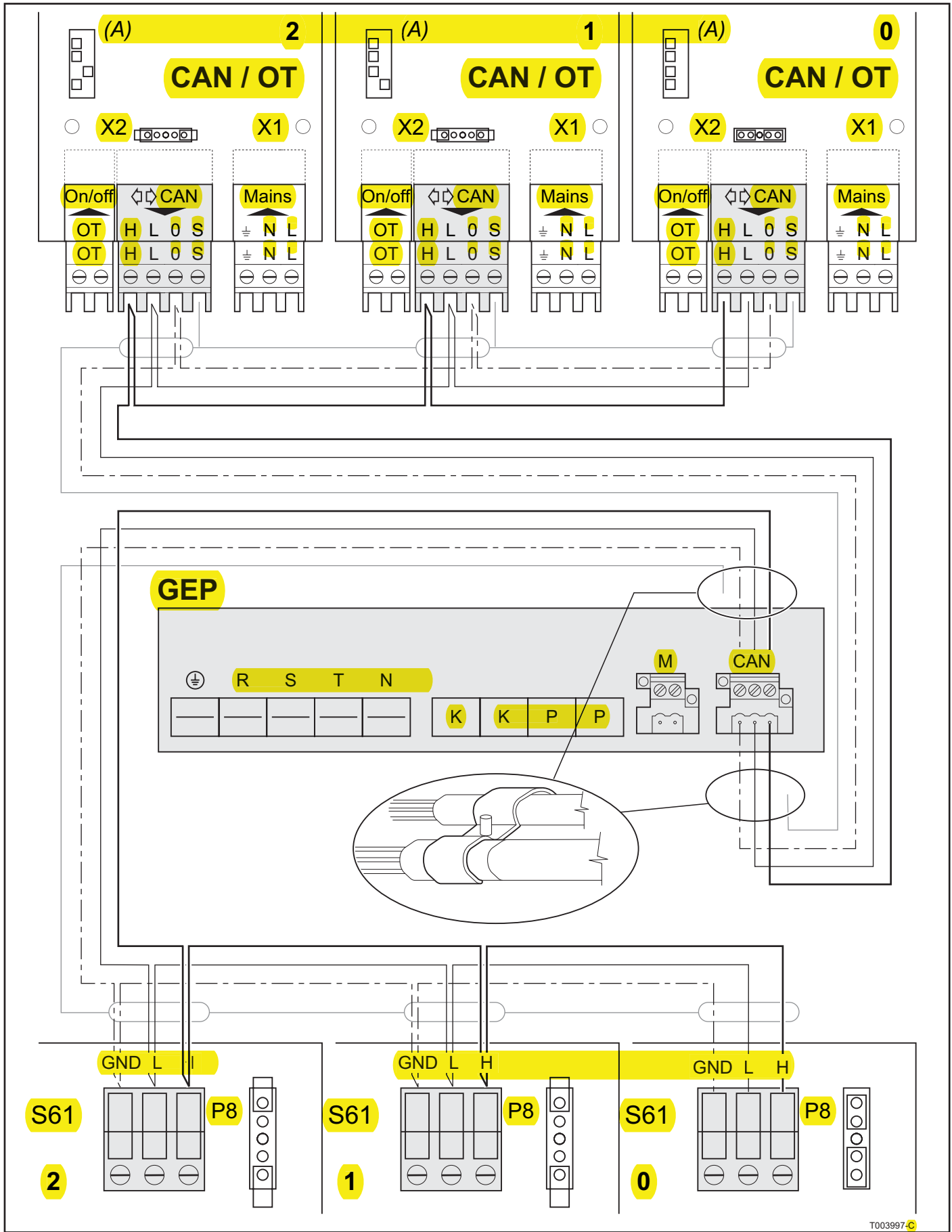

Fig. 31 Example of a one skid CAN-bus configuration

T003997-C

The following table indicates which jumpers need to be configured together with the address in the device.

Unit address	Jumper 1 position	Jumper 2 position	Jumper 3 position	Jumper 4 position
0	OFF	OFF	OFF	OFF
1	OFF	OFF	OFF	ON
2	OFF	OFF	ON	OFF
3	OFF	OFF	ON	ON
4	OFF	ON	OFF	OFF
5	OFF	ON	OFF	ON
6	OFF	ON	ON	OFF
7	OFF	ON	ON	ON
8	ON	OFF	OFF	OFF
9	ON	OFF	OFF	ON
10	ON	OFF	ON	OFF
11	ON	OFF	ON	ON
12	ON	ON	OFF	OFF
13	ON	ON	OFF	ON
14	ON	ON	ON	OFF
15	ON	ON	ON	ON

Table 08 Address table

7.5.5 LED signals for CAN-OT interface

If several faults occur simultaneously, the LED signalling will display each fault in order of priority, until the problem is resolved. The following list shows the order of priority. LED status 0 has the highest priority.

LED on	No errors OpenTherm and CAN-bus communication working
LED flashes	2x: No OpenTherm communication 3x: No CAN-bus communication 4x: Incorrect CAN-bus address settings 5x: Internal error 6x: CAN device is not supported
LED off	No voltage Faulty

Table 09 LED signals for CAN-OT interface

7.5.6 Setting CAN-bus address on the heat pump

In order to operate several heat pumps in a CAN-bus network combined with CAN-OT interfaces, each heat pump must be allocated a clear code. This can be done by setting parameter 40 in menu 5 for the heat pumps.

Parameter 40 is the printed circuit code and identifies the device in the CAN network. Each heat pump is given a unique code, independent of its position in the system. The value that needs to be set for parameter 40 is the numerical code assigned to the device and can vary from 0 to 478.

Set parameter 40 as follows:

1. Remove the front casing of the heat pump by unscrewing and removing the screws.
2. Remove the cover plate of the electrical panel to be able to access the set-up button.

Remeha Gas HP 35 A (LT/HT)

3. Insert the supplied key in the set-up button to access the control menus and the parameters.
4. Press the button once to display the available menus; the display shows the first menu as "0" (menu 0).
5. Rotate the button clockwise to display the other menus; the display then shows "1", "2", "3", "4", "5", "6", "7", "8" and "E".
6. Rotate the button to menu 5 to set the CAN-bus address. Press the button to make a selection or to confirm.
7. Enter access code 2222 to access menu 5. Rotate the button to 2 and press to confirm. Repeat this until you have entered the full access code.
8. Rotate the button to parameter 40 and press to confirm. Now enter the CAN-bus address for the heat pump. Rotate the button to the number to be entered and press to confirm. Repeat this action until the complete address has been entered.
9. Go to menu E and press the button to leave the control menus.
10. Replace the cover plate for the switch box and the front casing.

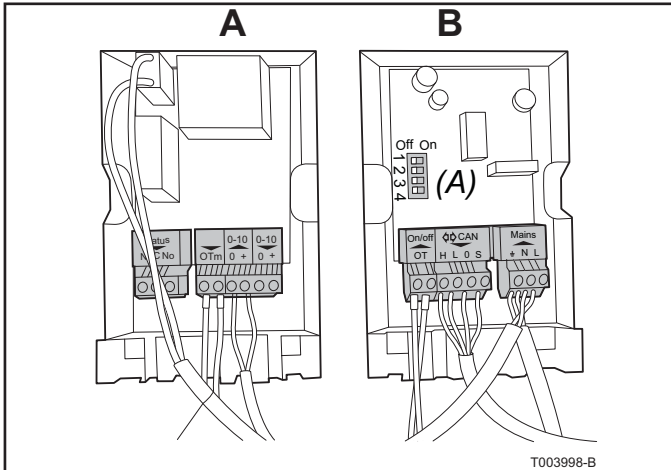

Fig. 32 OT-0-10V interface and CAN-OT interface without cover plate

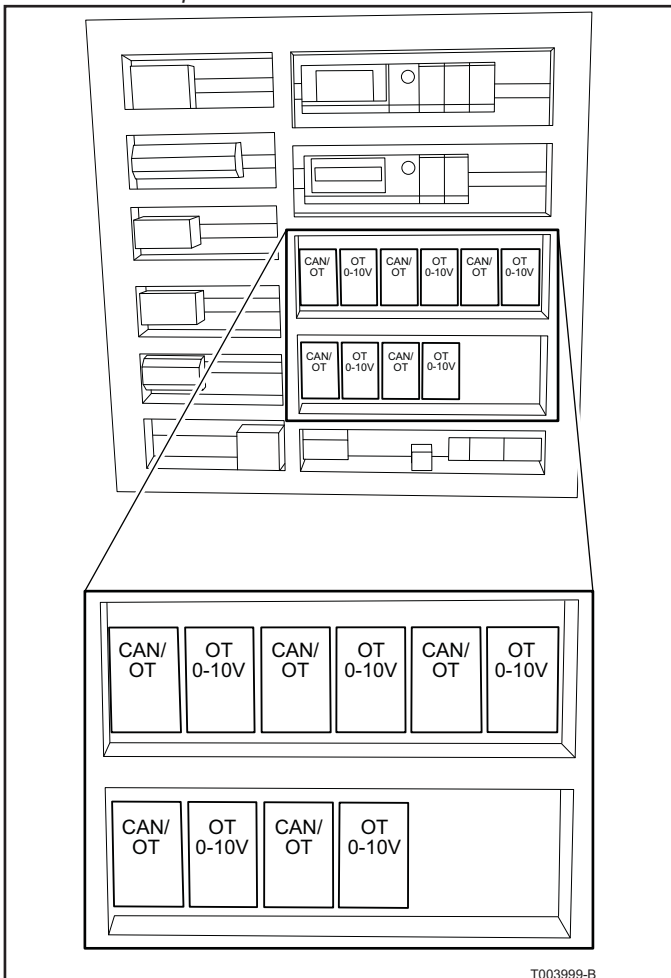

Fig. 33 Example of five CAN-bus/OT and five OT/0-10 V interfaces in an external switch box

7.5.7 Connecting the Remeha OpenTherm controller
Use two-wire cables to connect each CAN-OT interface to the corresponding terminals of the OpenTherm (cascade) controller. A simple 2 x 0.5 mm unprotected cable can be used. OpenTherm is not susceptible to polarity, so the wires can be swapped.

7.5.8 Connecting a water circulation pump
Each heat pump unit on the skid controls its own circulation pump. See the *Installation and service manual* for the heat pump for the connections. If a Rematic MC controller is used, a secondary system pump can be controlled on and off (230 V, max. 400 VA). If no Rematic MC is used, then a system controller from another manufacturer must be used to control the secondary system pump.

7.5.9 Controlling the heat pumps via a 0-10 V signal
The heat pumps can be controlled via a 0-10 V signal, which allows the heat pumps to be modulated between 50 and 100% output. Each unit is connected separately to a 0-10 V signal. The 0-10 V control is an expansion of the OpenTherm control. An OT-0-10V interface is connected to each CAN-OT interface. This OT-0-10V interface is available as an accessory; for the connection options see section 7.6. Fit the interfaces in pairs in the boiler room, not in the unit; preferably in a switch box. This is because the CAN-bus cable can be used over a longer distance without problems than the individual OpenTherm cables.

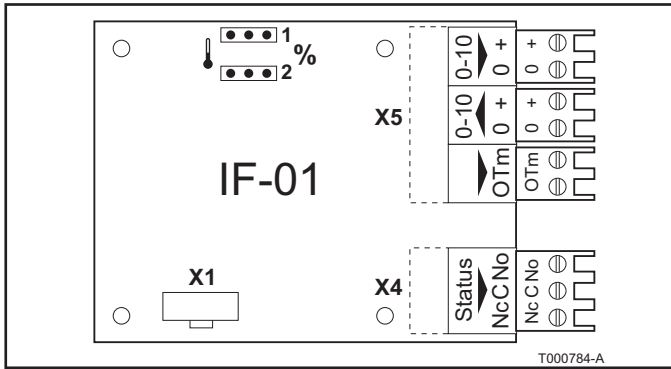

Fig. 34 The 0-10 V control PCB (IF-01)

7.6 Connection options for the 0-10 V control PCB (IF-01)

The IF-01 control PCB can be built into the switch box in the boiler room. See the instructions provided with the product.

7.6.1 Connection status (Nc)

If the appliance locks out, a relay is de-energised and the alarm can be transmitted via a potential-free contact (maximum 230 V, 1 A) on terminals **Nc** and **C** of the connector.

7.6.2 Connection (OTm)

The interface uses OpenTherm to communicate with the CAN/OT interface. To make this possible, the OTm connection must be connected to the OpenTherm input OT of this interface.

7.6.3 Analogue input (0-10 V)

This control can be based on temperature or heat output. The two controls are described briefly below. Connect the 0 - 10 V signal to the interface for analogue control.

7.6.4 Analogue control based on temperature (🌡️)

The 0-10 V signal controls the boiler flow temperature between 0°C and 100°C. This control modulates on the basis of flow temperature, where the heat output varies between the minimum and maximum values on the basis of the set point flow temperature calculated by the controller.

A jumper (2) on the interface is used to select either temperature (🌡️) or heat output (%).

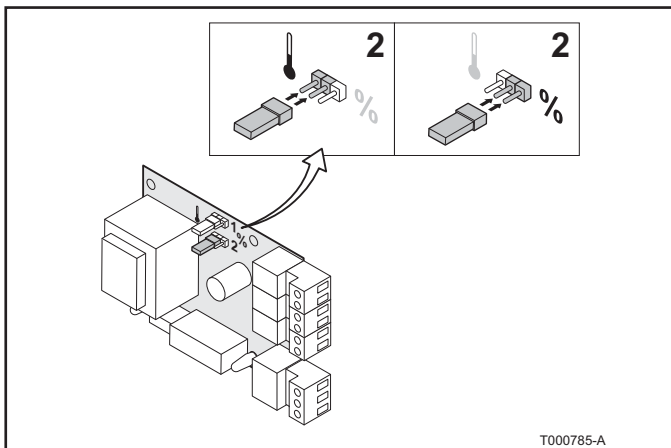

Fig. 35 Setting control based on temperature (🌡️) or heat output (%)

Jumper 2	Input signal (V)	Temperature (°C)	Description
🌡️	0 - 1.5	0 - 15	Boiler off
	1.5 - 1.8	15 - 18	Hysteresis
	1.8 - 10	18 - 100	Desired temperature

7.6.5 Analogue control based on heat output (%)

The 0-10 V signal controls the unit output between 0% and 100%, where the minimum and maximum values are limited. The minimum output is linked to the modulation depth of the appliance. The output varies between the minimum and maximum value on the basis of the value defined by the controller.

Jumper 2	Input signal (V)	Heat output (%)	Description
🌡️	0 - 2.0 ⁽¹⁾	0 - 20	Boiler off
	2.0 - 2.2 ⁽¹⁾	20 - 22	Hysteresis
	2.0 - 10 ⁽¹⁾	20 - 100	Desired heat output

⁽¹⁾ Depends on the minimum modulation depth (standard 50%)

Remeha Gas HP 35 A (LT/HT)

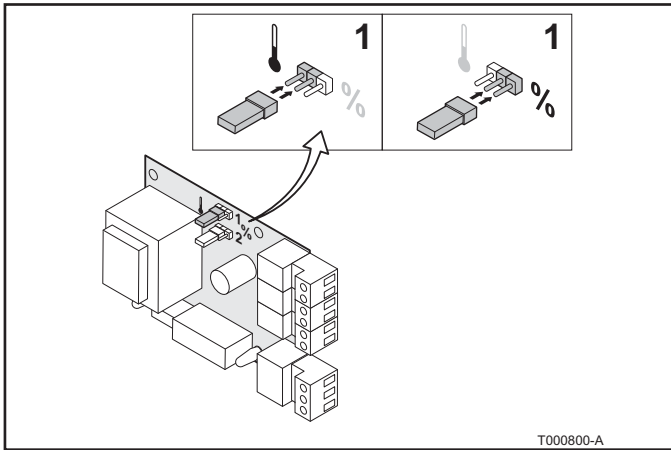

Fig. 36 Setting feedback based on temperature (🌡️) or heat output (%)

7.6.6 Analogue output (0-10 V)

This feedback can be based on temperature or heat output. The two controls are described briefly below.

A jumper (1) on the interface is used to select either temperature (🌡️) or heat output (%).

Jumper 1	Output signal (V)	Temperature (°C)	Description
🌡️	0.5	-	Alarm
	1 - 10	10 - 100	Supplied temperature

Jumper 1	Output signal (V)	Temperature (°C)	Description
🌡️	0		Boiler off
	0.5		Alarm
	5.0 - 10 ⁽¹⁾	50 - 100	Supplied heat output

⁽¹⁾ Depends on the minimum modulation depth (standard 50%)

8 COMMISSIONING AND LEGISLATION

8.1 Introduction

The Remeha Gas HP heat pump is subject to the legislation and regulations for both gas-fired systems and refrigeration systems. The latter is due to the ammonia/water solution that is used as a coolant. This chapter sets out the main points to consider when commissioning the heat pump system.

8.2 Regulations and application

In addition to the legislation and regulations for gas-fired systems, the following regulations regarding refrigeration systems are applicable:

- Pressure Equipment Directive (97/23/EG)
- EN 378
- Commodities Act, Pressure Equipment (Commodities Act) Decree and corresponding regulations
- Publication Series on Dangerous Substances: Ammonia as refrigerant in refrigeration systems and heat pumps (PGS 13; 2009)
- Working Conditions Act, Working Conditions Decree and regulations
- Building Decree
- Environmental Management Act

Remeha has attempted to translate this specific, and sometimes contradictory, legislation into practical points to consider:



WARNING

Remeha is not responsible for differences in interpretation with the competent authority.

- EBI and PI inspections are necessary if the output of the complete system is > 100 kW. The reinspection interval is in accordance with the prescribed methods (SCIOS)
- A commissioning inspection (IGK) is mandatory according to the Commodities Act.
- Reinspection IGK every four years. When the Gas HP heat pump is used on or in a residential or utility building, its installation falls under the rules for a type B company. This entails an obligation to report the matter to the competent authority (municipal environmental department).
- In the PGS 13: 2009, page 21 of chapter 5 sets out the reasons why the principle of equality applies to the Remeha Gas HP heat pumps.
- The ADR (European Agreement concerning the International Carriage of Dangerous Goods by Road) does not apply when using road transport for a system containing a dangerous substance.
- When storing several heat pumps, there must never be more than 1000 kg ammonia/water mixture present in one location.

8.3 Points to consider regarding the configuration

8.3.1 General

- A log book must be available during the technical installation of the system. The log book of the Netherlands Association of Refrigeration Engineering and Air Treatment Companies (NvKL) meets the legal requirements, provided that the safety document referred to in 2.5 is added.

8.3.2 Outside configuration

- The area in which the system is located must not be freely accessible.
- In the event of leakage of the ammonia and water mixture, it must not be possible for the vapour to be spread (e.g. by other fans).

8.3.3 Version and scope of delivery of heat pump

- The heat pump is equipped with double spring-loaded pressure relief valves, including shut-off valves. The original test certificates for the pressure relief valves must also be supplied.
- The outside of the heat pump carries a warning about toxic danger.
- The installer must fit the heat pump with a maintenance switch.
- Operating and maintenance instructions must be provided in the correct language.
- A CE-certificate with all relevant modules in accordance with PED (class 3) is supplied.

8.4 Points to consider when operating the system

- An annual inspection and service is mandatory (EN 378)
- The engineers must have proven knowledge of how to handle ammonia mixtures, including in the event of an emergency.
- The actions must be recorded in a log book kept in the machine room.
- Work instructions must also be provided, including instructions on how to act in the event of an emergency.
- Sufficient personal protective equipment must be provided to protect engineers from contact with ammonia. This includes masks with filter cartridges suitable for ammonia and protective gloves.
- The engineers or the machine room must be equipped with an eyewash.

8.5 Other

- When a Commissioning Inspection based on the Commodities Act is carried out, a PGS 13 inspection must also take place. The AKII can then provide a draft text for the general safety document.
- The obligations of the user must be stated during the sales process and must be specified in the system's user manual (by the installer). These obligations are as follows:
 - To submit a report to the competent authority within the context of the Activities Decree.
 - To draw up a general explosion protection document.
 - The system is subject to reinspections on the basis of the Pressure Equipment (Commodities Act) Decree.

9 INSPECTION AND MAINTENANCE

See the *Installation and service manual* for the heat pump.

	After every 6000 operating hours or every year*	After every 12,000 operating hours or every four years*	After every 24,000 operating hours or every eight years*
Condensation/absorption interchangeable battery	Clean	-	-
Oil in hydraulic pump	Check oil level	Replace	-
Belts and pulley for hydraulic pump	Check tension (manually)	Replace	-
Flue gas condensate siphon	Check and clean	-	-
Flue gas discharge pipes	Check	-	-
Burner	-	Check and clean	-
Burner sealing	-	Replace	-
Ignition electrode	-	Check	-
Flame sensor	-	Check	-
Combustion chamber and generator fins	-	Check	Check and clean
Condenser or hydraulic pump	-	-	Replace
Safety valve for ammonia/water circuit		Replace ⁽¹⁾	

* *Whichever occurs first*

⁽¹⁾ *by a certified body*

Table 10 *Maintenance programme*

© Copyright

All technical and technological information contained in these technical instructions, as well as any drawings and technical descriptions supplied, remain our property and shall not be multiplied without our prior consent in writing.

230112



Remeha Commercial
Remeha House
Molly Millars Lane
Wokingham
Berkshire
RG41 2QP

Tel: 0118 9783434
Fax: 0118 9786977